

THIS DRAWING IS UNPUBLISHED. RELEASED FOR PUBLICATION
 © COPYRIGHT - By - ALL RIGHTS RESERVED.

LOC	DIST	REVISIONS					
		P	LTR	DESCRIPTION	DATE	DWN	APVD
-	-		H1	NEW DRAWING PER ECO-11-019045	27MAR12	KH	DR

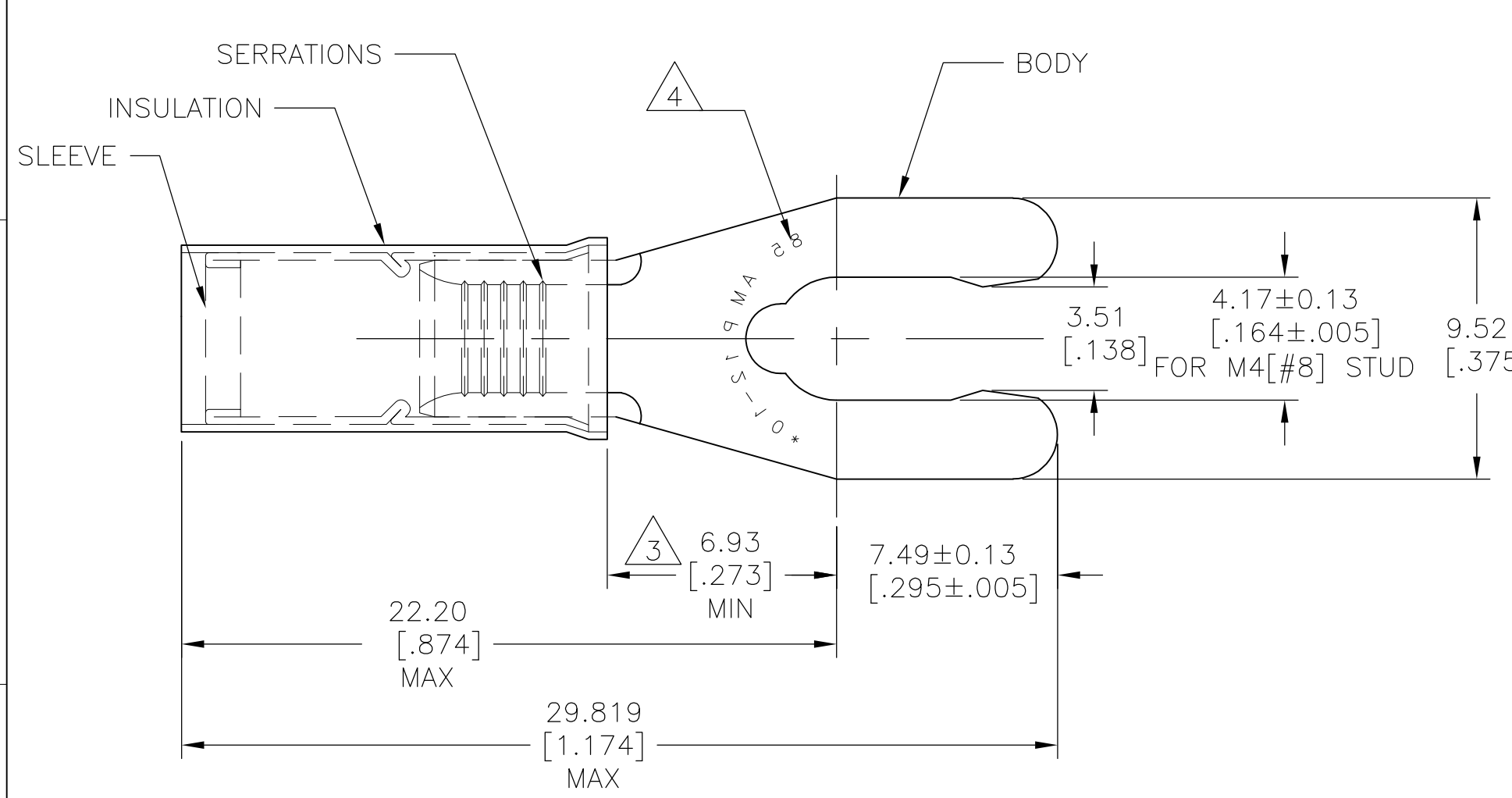

AMP WIRE RANGE	Listed FILE E13288
12-10 AWG SOLID OR STRANDED	12-10 AWG SOLID OR STRANDED

- 1 FOR WIRE INSULATION DIA:
3.81[.150] TO 6.35[.250]
- 2 TONGUE MATERIAL THK: 0.98±0.05[.0385±.0020]
- 3 DIMENSION APPLIES FROM EDGE OF METAL WIRE BARREL TO CENTER OF STUD.
- 4 STAMP 85 AMP 12-10* APPROX AS SHOWN
- 5 MATERIAL:
BODY: PHOSPHOR BRONZE PER ASTM B139
SLEEVE: COPPER PER ASTM B152
INSULATION: NYLON.
- 6 FINISH:
BODY&SLEEVE: TIN PLATE PER ASTM B545
INSULATION: COLOR-YELLOW

2500	ON TAPE REEL	52431-3
500	LOOSE PIECE	52431-1
QTY	PACKAGE TYPE	PART NO

AMP INCORPORATED
CUSTOMER SERVICE SYSTEMS

FOR ADDITIONAL PRODUCT INFORMATION OR COPIES OF DRAWINGS AND TECHNICAL DOCUMENTS
 PRODUCT INFORMATION CENTER
 1-800-522-6752

FOR APPLICATION TOOLING INFORMATION
 TOOLING ASSISTANCE CENTER
 1-800-722-1111

FOR ORDER ENTRY
 1-800-526-5142

RECOMMENDED OPERATING TEMPERATURE:
 105°C [221°F]

VOLTAGE RATING:
 300V MAX

WIRE CROSS SECTIONAL AREA RANGE:
 2.62-6.64mm² [5,180-13,100]
 SOLID OR STRANDED

THIS DRAWING IS A CONTROLLED DOCUMENT.

DIMENSIONS:
mm [INCHES]

TOLERANCES UNLESS OTHERWISE SPECIFIED:

0 PLC	± -
1 PLC	± -
2 PLC	± 0.20[.008]
3 PLC	± -
4 PLC	± -
ANGLES	± 5°

MATERIAL

FINISH

DWN KIRAN HOLAL 27MAR12	TE Connectivity	NAME		
CHK ROHDE DANIEL 27MAR12		WIRE TERMINAL P.I.D.G SPRING SPADE WIRE SIZE: 12-10		
APVD ROHDE DANIEL 27MAR12		SIZE	CAGE CODE	DRAWING NO
PRODUCT SPEC		A3	00779	C-52431
APPLICATION SPEC	RESTRICTED TO	-		
WEIGHT	CUSTOMER DRAWING			
SCALE 8:1		SHEET 1 OF 1	REV H1	