

# Hardware Reference Manual

REV. July 2018

---

## Condor (VL-EPU-4460)

Intel Core\* 6xxx-based  
Embedded Processing Unit with  
SATA, Dual Ethernet, USB,  
Digital I/O, Serial, Video, Mini  
PCIe Sockets, SPX, Trusted  
Platform Module.





[WWW.VERSALOGIC.COM](http://WWW.VERSALOGIC.COM)

12100 SW Tualatin Road  
Tualatin, OR 97062-7341  
(503) 747-2261  
Fax (971) 224-4708

Copyright © 2017-2018 VersaLogic Corp. All rights reserved.

**Notice:**

Although every effort has been made to ensure this document is error-free, VersaLogic makes no representations or warranties with respect to this product and specifically disclaims any implied warranties of merchantability or fitness for any particular purpose.

VersaLogic reserves the right to revise this product and associated documentation at any time without obligation to notify anyone of such changes.

\* Other names and brands may be claimed as the property of others.

## Product Revision Notes

Revision 1.0	Initial Release
Revision 1.1	Removed incorrect heat plate image
Revision 1.2	Updated Power Pinout diagram (Figure 18)
Revision 1.3	Updated J11 pinout (Table 14)

## Support Page

The [Condor Support Page](#) contains additional information and resources for this product including:

- Operating system information and software drivers
- Data sheets and manufacturers links for chips used in this product
- BIOS information and upgrades

## VersaTech KnowledgeBase

The [VersaTech KnowledgeBase](#) contains useful technical information about VersaLogic products, along with product advisories.

## Customer Support

If you are unable to solve a problem after reading this manual, visiting the product support page, or searching the KnowledgeBase, contact VersaLogic Technical Support at (503) 747-2261. VersaLogic support engineers are also available via e-mail at [Support@VersaLogic.com](mailto:Support@VersaLogic.com).

## Repair Service

If your product requires service, you must obtain a Returned Material Authorization (RMA) number by calling 503-747-2261. Be ready to provide the following information:

- Your name, the name of your company, your phone number, and e-mail address
- The name of a technician or engineer that can be contacted if any questions arise
- The quantity of items being returned
- The model and serial number (barcode) of each item
- A detailed description of the problem
- Steps you have taken to resolve or recreate the problem
- The return shipping address

**Warranty Repair** All parts and labor charges are covered, including return shipping charges for UPS Ground delivery to United States addresses.

**Non-warranty Repair** All approved non-warranty repairs are subject to diagnosis and labor charges, parts charges and return shipping fees. Specify the shipping method you prefer and provide a purchase order number for invoicing the repair.

**Note:** Mark the RMA number clearly on the outside of the box before returning.

## Cautions

### Electrostatic Discharge



**CAUTION:**

Electrostatic discharge (ESD) can damage circuit boards, disk drives, and other components. The circuit board must only be handled at an ESD workstation. If an approved station is not available, some measure of protection can be provided by wearing a grounded antistatic wrist strap. Keep all plastic away from the board, and do not slide the board over any surface.

After removing the board from its protective wrapper, place the board on a grounded, static-free surface, component side up. Use an antistatic foam pad if available.

The board should also be protected inside a closed metallic antistatic envelope during shipment or storage.

**Note:** The exterior coating on some metallic antistatic bags is sufficiently conductive to cause excessive battery drain if the bag comes in contact with the bottom side of the Condor.

### Handling Care



**CAUTION:**

Avoid touching the exposed circuitry with your fingers when handling the board. Though it will not damage the circuitry, it is possible that small amounts of oil or perspiration on the skin could have enough conductivity to cause the contents of CMOS RAM to become corrupted through careless handling, resulting in CMOS resetting to factory defaults.

### Earth Ground Requirement



**CAUTION:**

All mounting standoffs should be connected to earth ground (chassis ground). This provides proper grounding for EMI purposes.

# Contents

---

Cautions .....	iv
Electrostatic Discharge .....	iv
Handling Care .....	iv
Earth Ground Requirement .....	iv
<b>Introduction .....</b>	<b>9</b>
Features .....	10
Technical Specifications .....	10
Block Diagram .....	11
Dimensions and Mounting .....	12
Condor Dimensions .....	12
<b>Configuration and Setup .....</b>	<b>13</b>
Initial Configuration .....	13
Basic Setup .....	13
BIOS Setup Utility .....	14
Default BIOS Setup Values .....	14
Operating System Installation .....	14
Jumper Blocks .....	15
Jumper Configuration Summary .....	15
<b>Board Features .....</b>	<b>16</b>
CPU .....	16
CPU Die Temperature .....	16
System RAM .....	16
Real-Time Clock (RTC) .....	16
External Connectors .....	17
Power Delivery .....	18
Main Power Connector .....	18
Cabling .....	19
Power Requirements .....	19
Power Delivery Considerations .....	19
Power Button .....	20
Supported Power States .....	20
Battery Power Options .....	21
External Speaker .....	22
Push-button Reset .....	22
CPU Fan Connector .....	23
Cabling .....	24
<b>Mass Storage Interfaces .....</b>	<b>25</b>
SATA Interface .....	25
<b>Multi-purpose I/O .....</b>	<b>26</b>
USB Interfaces .....	26
Mini PCIe Sockets .....	27
W_DISABLE# Signal .....	29

Mini PCIe Card Wireless Status LEDs.....	30
SATA Activity LED.....	31
User I/O Connector.....	32
Cabling.....	33
SPX* Expansion Bus.....	34
Cabling.....	35
<b>Serial I/O .....</b>	<b>36</b>
Serial Ports.....	36
Serial Port Connector Pinout.....	37
Cabling.....	37
COM Port Configuration.....	37
Console Redirection .....	37
<b>Video Interfaces.....</b>	<b>38</b>
Mini DisplayPort++ Connectors.....	38
VGA Output.....	40
LVDS Interface.....	41
LVDS Flat Panel Display Connectors.....	41
LVDS Backlight Connector.....	44
<b>Network Interfaces .....</b>	<b>45</b>
Ethernet Connector.....	45
Cabling.....	46
Ethernet Status LED .....	47
<b>VL-CBR-4005B Paddleboard.....</b>	<b>48</b>
VL-CBR-4005B Connectors and Indicators.....	48
User I/O Connector.....	49
Cabling.....	50
On-board Battery .....	50
Auxiliary I/O Connector.....	51
Dimensions and Mounting Holes .....	52
<b>Thermal Considerations .....</b>	<b>53</b>
Selecting the Correct Thermal Solution for Your Application .....	53
Heat Plate.....	53
System-level Considerations .....	53
CPU Thermal Trip Points.....	54
Thermal Specifications, Restrictions, and Conditions .....	55
Overall Restrictions and Conditions:.....	55
Heat Plate Only Restrictions and Conditions:.....	55
Heat Sink Only Considerations: .....	55
Heat Sink with Fan Considerations: .....	56
EPU-4460 Thermal Characterization .....	56
Test Results.....	57
Installing VersaLogic Thermal Solutions.....	59
Hardware Assembly.....	59
Installing the VL-HDW-416 Passive Heat Sink.....	60
Installing the VL-HDW-415 Heat Sink Fan.....	62

## Figures

Figure 1. The Condor (VL-EPU-4460) .....	9
Figure 2. Condor (VL-EPU-4460) Block Diagram .....	11
Figure 3. Condor Dimensions and Mounting Holes .....	12
Figure 4. Jumpers As-Shipped Configuration .....	15
Figure 5. Top Baseboard Connector Locations .....	17
Figure 6. Main Power Connector Pin Orientation .....	18
Figure 7. Location and Pin Orientation of the Battery Connector .....	21
Figure 8. VL-CBR-0203 Latching Battery Module .....	22
Figure 9. Location and Pin Orientation of the CPU Fan Connector .....	23
Figure 10. Location of the SATA Connector .....	25
Figure 11. Location of the USB Ports .....	26
Figure 12. Location of Mini PCIe Sockets .....	27
Figure 13. Mini PCIe Wireless Status LEDs .....	30
Figure 14. Location of the SATA/mSATA Activity LED .....	31
Figure 15. Location and Pin Orientation of the User I/O Connector .....	32
Figure 16. SPX Connector Location and Pin Configuration .....	34
Figure 17. Location and Pin Orientation of the Serial I/O Connectors .....	36
Figure 18. Location of the Mini DisplayPort++ Connectors .....	39
Figure 19. VL-CBR-2032 Mini DisplayPort to VGA Adapter .....	40
Figure 20. Location of the LVDS Connectors .....	41
Figure 21. Location and Pin Orientation of the Ethernet Connector .....	45
Figure 22. Onboard Ethernet Status LEDs .....	47
Figure 23. VL-CBR-4005B Connectors, Switches, and LEDs .....	48
Figure 24. Location and Pin Orientation of the User I/O Connector .....	49
Figure 25. Location and Pin Orientation of Auxiliary I/O Connector .....	51
Figure 26. VL-CBR-4005B Dimensions and Mounting Holes .....	52
Figure 27. EPU-4460-EAP Dual Core Temperature Relative to Ambient Temperature .....	57
Figure 28. EPU-4460-EBP Dual Core Temperature Relative to Ambient Temperature .....	58
Figure 29. EPU-4460-ECP Dual Core Temperature Relative to Ambient Temperature .....	59
Figure 30. Heat Plate Down .....	60
Figure 31. Installing the Passive Heat Sink .....	60
Figure 32. Installing the Heat Sink Fan .....	62

## Tables

Table 1. Jumper Block Configurations .....	15
Table 2. Condor Memory Characteristics .....	16
Table 3. Main Power Connector Pinout .....	19
Table 4. Supported Power States .....	20
Table 5. CPU Fan Connector Pinout .....	23
Table 6. Mini PCIe Socket 1 / mSATA Socket Pinout .....	28
Table 7. Mini PCIe Card Wireless Status LEDs .....	30
Table 8. User I/O Connector Pinout and Pin Orientation .....	33
Table 9. SPX Connector Pinout .....	35
Table 10. COM1/COM2 Connector Pinout .....	37
Table 11. Mini DisplayPort++ Connector Pinout .....	39
Table 12. LVDS Flat Panel Display Connector Pinout .....	42
Table 13. LVDS Backlight Connector Pinout .....	44
Table 14. Ethernet Connector Pinout .....	46

Table 15. User I/O Connector Pinout .....	49
Table 16. Auxiliary I/O Connector Pinout .....	51
Table 17. CPU Thermal Trip Points.....	54
Table 18. Temperature Monitoring Programs .....	55
Table 19. Absolute Minimum and Maximum Air Temperatures.....	55
Table 20. EPU-4460 Thermal Testing Setup.....	56



# Introduction

# 1

Figure 1. The Condor (VL-EPU-4460)

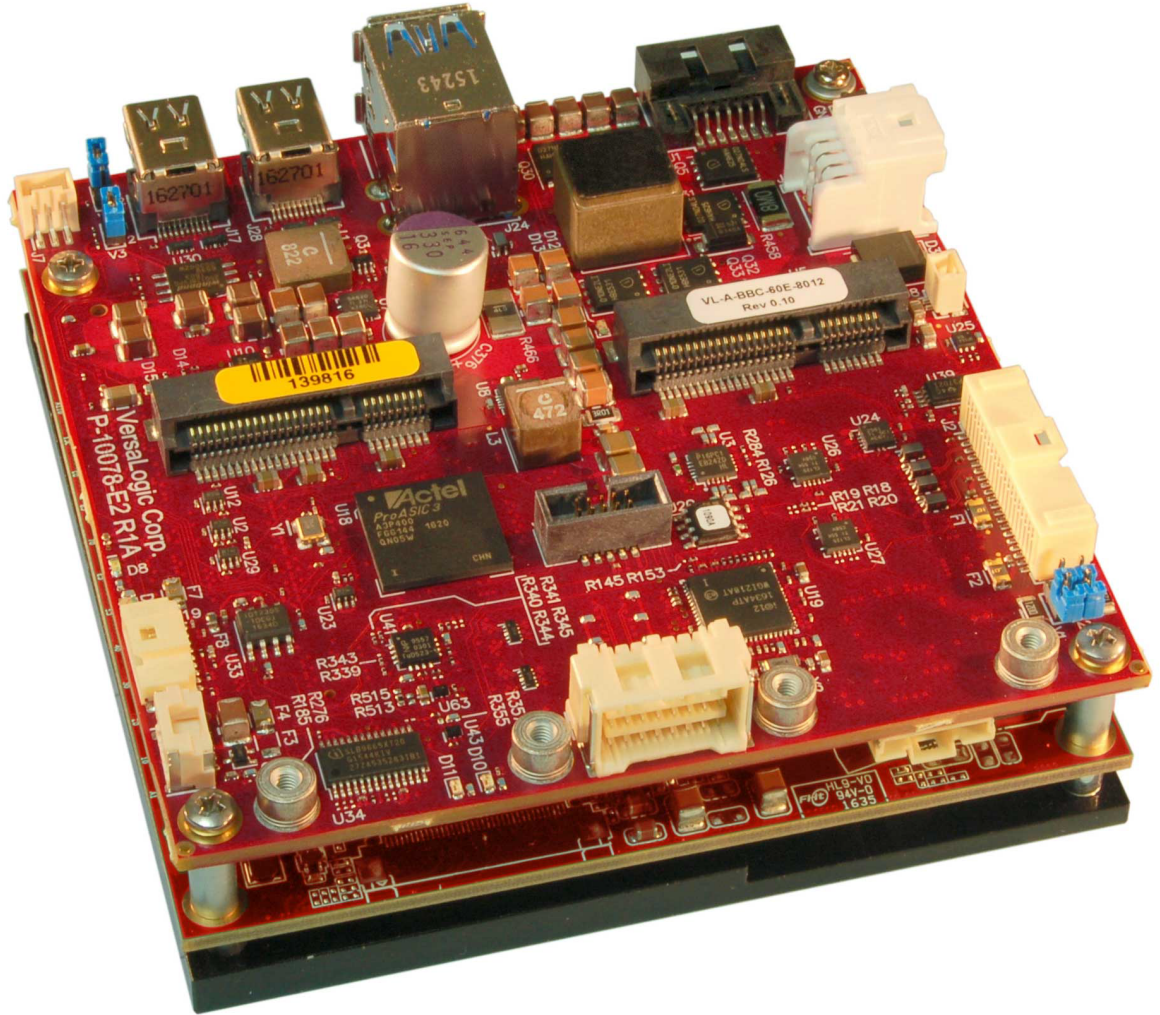

## Features

The Condor (VL-EPU-4460) is a feature-packed Embedded Processing Unit (EPU) engineered and tested to meet the embedded industry's evolving requirements to develop smaller, lighter, and lower power embedded systems while adhering to stringent regulatory standards.

This embedded computer, equipped with an Intel Core\* 6xxx processor, is designed to withstand extreme temperature, impact, and vibration. Its features include:

- Intel Core\* i3-6100 (2.3 GHz, Dual Core), i5-6300 (2.4GHz, Dual Core), or i7-6600 (2.6 GHz, Dual Core) processor
- Up to 32 GB DDR4 RAM
- Two auto-detect 10BaseT/100BaseTX/1000BaseT Ethernet ports with network boot support (Port 1 only)
- Integrated Intel HD 520\* Graphics Gen 9 core supports DirectX\* 12, OpenGL 4.4, and H.264, MPEG-2 encoding/decoding. Dual Mini DisplayPort and LVDS video outputs. LVDS backlight control
- Four USB 2.0 host ports, two USB 3.0/2.0 port
- Two RS-232/422/485 COM ports
- Wide input voltage range (8 – 30V)
- Input under-voltage and over-voltage protection
- I<sup>2</sup>C support
- Two Mini PCIe sockets
- Full ACPI support
- 6 Gb/s SATA port support bootable SATA hard drives
- Watchdog Timer, prescaler of approximately 1 μs to 10 minutes.
- Standard heat plate with optional thermal solutions
- Field upgradeable AMI UEFI BIOS with enhancements
- RoHS compliant
- Extended temperature operation
- Customization available
- Trusted Platform Module

The Condor is compatible with popular operating systems including Microsoft Windows\*/WES7, and Linux (see the [VersaLogic OS Compatibility Chart](#)).

Condor EPUs receive 100% functional testing and are backed by a limited five-year warranty. Careful parts sourcing and US-based technical support ensure the highest possible quality, reliability, service, and product longevity for this exceptional EPU.

## Technical Specifications

Refer to the [Condor Data Sheet](#) for complete specifications. Specifications are subject to change without notification.



## Dimensions and Mounting

### Condor Dimensions

**Figure 3. Condor Dimensions and Mounting Holes**

*(Not to scale. All dimensions in millimeters.)*

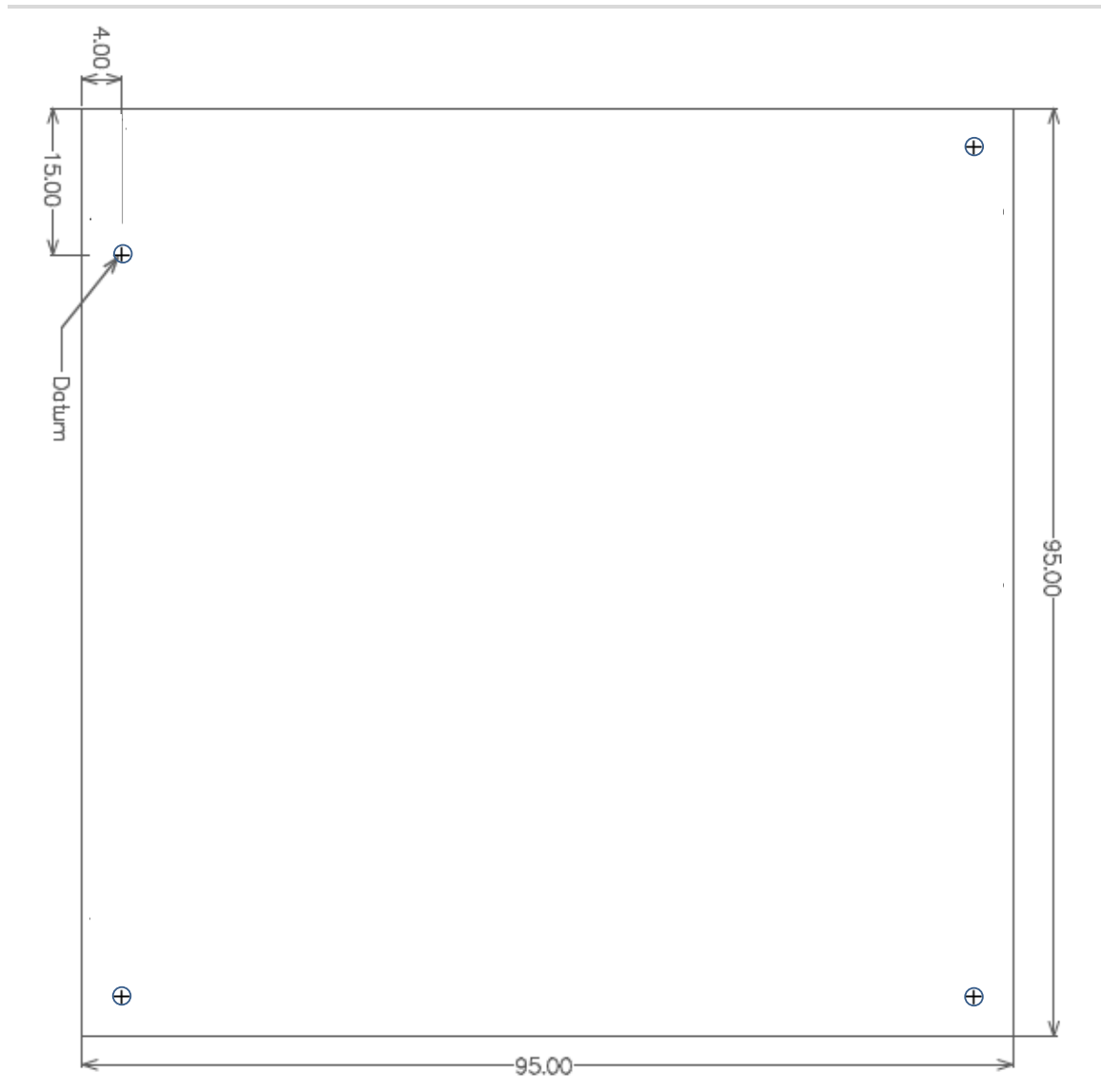

## Initial Configuration

The following components are recommended for a typical development system with the Condor EPU:

- ATX power supply
- VL-CBR-4005B paddleboard and VL-CBR-4005A cable. Refer to the chapter titled “VL-CBR-4005B Paddleboard”, beginning on page 48 for details on the VL-CBR-4005B paddleboard.
- USB keyboard and mouse
- SATA hard drive
- USB CD-ROM drive
- VGA monitor and a VL-CBR-2032 Mini DisplayPort-to-VGA adapter
- A thermal solution (using either VersaLogic accessories or a customer-designed solution)

You will also need an operating system (OS) installation CD-ROM.

## Basic Setup

The following steps outline the procedure for setting up a typical development system. The Condor should be handled at an ESD workstation or while wearing a grounded antistatic wrist strap.

Before you begin, unpack the Condor and accessories. Verify that you received all the items you ordered. Inspect the system visually for any damage that may have occurred in shipping. Contact [Support@VersaLogic.com](mailto:Support@VersaLogic.com) immediately if any items are damaged or missing.

Gather all the peripheral devices you plan to attach to the Condor as well as their interface and power cables. Attach standoffs to the board to stabilize it and make it easier to work with.

The next figure shows a typical setup for the Condor in the development environment.

### 1. Attach Cables and Peripherals

- Attach a VGA monitor to the baseboard’s Mini DisplayPort++ connector using a VL-CBR-2032.
- Attach a SATA hard disk to the baseboard’s SATA connector using a VL-CBR-0702 cable.
- Attach a VL-CBR-4005B paddleboard to the baseboard’s User I/O connector.
- Connect a USB keyboard and USB mouse to the USB Type-A connectors on the VL-CBR-4005B paddleboard.
- Attach a USB CD-ROM drive to one of the USB Type-A connectors on the VL-CBR-4005B paddleboard.

## 2. Connect Power Source

- Plug the power adapter cable VL-CBR-0809 into the main power connector on the baseboard. Attach the motherboard connector of the ATX power supply to the adapter.
- Attach an ATX power cable to any drive that is not already attached to the power supply (hard drive or CD-ROM drive).

## 3. Install Thermal Solution

- See the Installing Thermal Solutions section

## 3. Review Configuration

- Before you power up the system, double-check all the connections. Make sure all cables are oriented correctly, that adequate power is supplied to the Condor and all attached peripheral devices.

## 4. Power On

- Turn on the ATX power supply and the video monitor. If the system is correctly configured, a video signal should be present.

## 5. Install Operating System

- Install the operating system according to the instructions provided by the operating system manufacturer.

# BIOS Setup Utility

Refer to the [VersaLogic System Utility Reference Manual](#) for information on how to configure the Condor BIOS.

The Condor permits you to store user-defined BIOS settings. This enables you to retrieve those settings from cleared or corrupted CMOS RAM, or battery failure. All BIOS defaults can be changed, except the time and date. BIOS defaults can be updated with the BIOS Update Utility.



**CAUTION:** If BIOS default settings make the system unbootable and prevent the user from entering the BIOS Setup utility, the Condor must be serviced by the factory.

## Default BIOS Setup Values

After CMOS RAM clears, the system loads default BIOS parameters the next time the board powers on. The default CMOS RAM setup values are used in order to boot the system whenever the main CMOS RAM values are blank, or when the system battery is dead or has been removed from the board.

# Operating System Installation

The standard PC architecture used on the Condor makes the installation and use of most of the standard x86-based operating systems very simple. The operating systems listed on the [VersaLogic Software Support](#) page use the standard installation procedures provided by the maker of the operating system. Special optimized hardware drivers for a particular operating system, or a link to the drivers, are available on the [Condor Support Page](#).

# Jumper Blocks

Figure 4. Jumpers As-Shipped Configuration

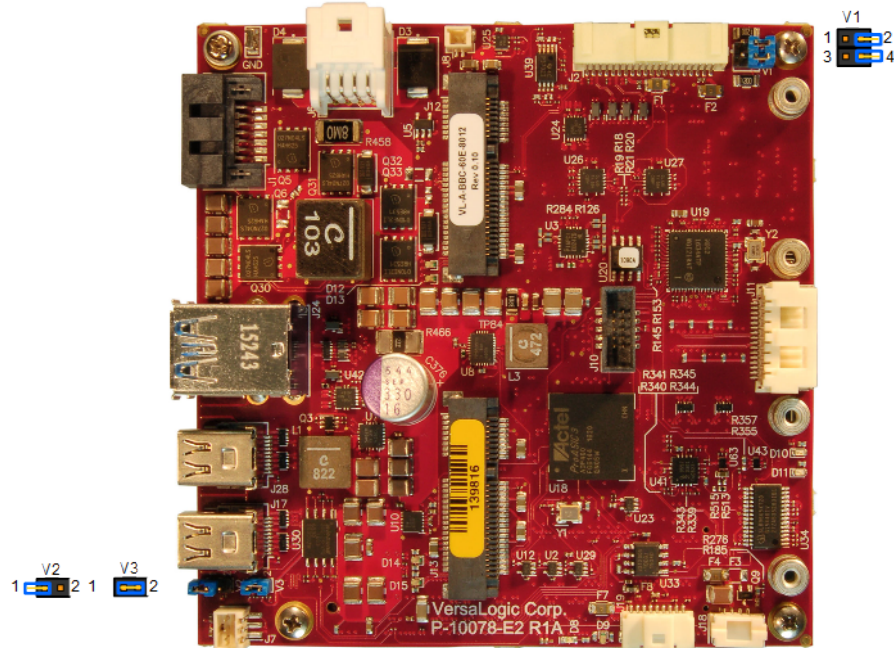

## Jumper Configuration Summary

Table 1. Jumper Block Configurations

Jumper Block	Pins	Function	Description
V1	1-2	COM1 Endpoint Termination	<ul style="list-style-type: none"> <li>Jumper In: Endpoint termination (for RS-485 or RS-422)</li> <li><b>Jumper Out: Not terminated (RS-232) (default)</b></li> </ul>
	3-4	COM2 Endpoint termination	<ul style="list-style-type: none"> <li>Jumper In: Endpoint termination (for RS-485 or RS-422)</li> <li><b>Jumper Out: Not terminated (RS-232) (default)</b></li> </ul>
V2	1-2	Primary/Backup BIOS Select	<ul style="list-style-type: none"> <li>Jumper In: Backup BIOS is selected</li> <li><b>Jumper Out: Backup BIOS is not selected (default)</b></li> </ul>
V3	1-2	Reserved	This jumper currently has no function. The jumper should be left in the uninstalled position or removed.

## CPU

The Intel Core 6xxx SoC features integrated 3D graphics, video encode and decode, and memory and display controllers in one package. The following CPU configurations are available:

- VL-EPU-4460-EAP: Intel Core 6100 – 2.3 GHz, Dual Core
- VL-EPU-4460-EBP: Intel Core 6300 – 2.4 GHz, Dual Core
- VL-EPU-4460-EDP: Intel Core 6600 – 2.6 GHz, Dual Core

### CPU Die Temperature

The CPU die temperature is affected by numerous conditions, such as CPU utilization, CPU speed, ambient air temperature, airflow, thermal effects of adjacent circuit boards, external heat sources, and many others.

The thermal management for the Intel 6xxx series of processors consists of a sensor located in the core processor area. The processor contains multiple techniques to help better manage thermal attributes of the processor. It implements thermal-based clock throttling and thermal-based speed step transitions. There is one thermal sensor on the processor that triggers Intel's thermal monitor (the temperature at which the thermal sensor triggers the thermal monitor is set during the fabrication of the processor). Triggering of this sensor is visible to software by means of the thermal interrupt LVT entry in the local APIC. (See the [Intel Core Processor U/Y Series Datasheet](#) for complete information.)

## System RAM

The Condor has socketed SDRAM with the following characteristics:

**Table 2. Condor Memory Characteristics**

Board Model	Memory Type	Capacity	Data Rate
VL-EPU-4460-EAP	DDR4	8 GB	2133 MT/s – Dual Channel
VL-EPU-4460-EBP	DDR4	16 GB	2133 MT/s – Dual Channel
VL-EPU-4460-ECP	DDR4	16 GB	2133 MT/s – Dual Channel

## Real-Time Clock (RTC)

The Condor features a real-time clock/calendar (RTC) circuit. The Condor supplies RTC voltage in S5, S3, and S0 states, but requires an external +2.75 V to +3.3 V battery connection. Refer to the section titled Battery Power Options on page 21 for more information. The BIOS Setup utility sets the RTC.



## External Connectors

Figure 5. Top Baseboard Connector Locations

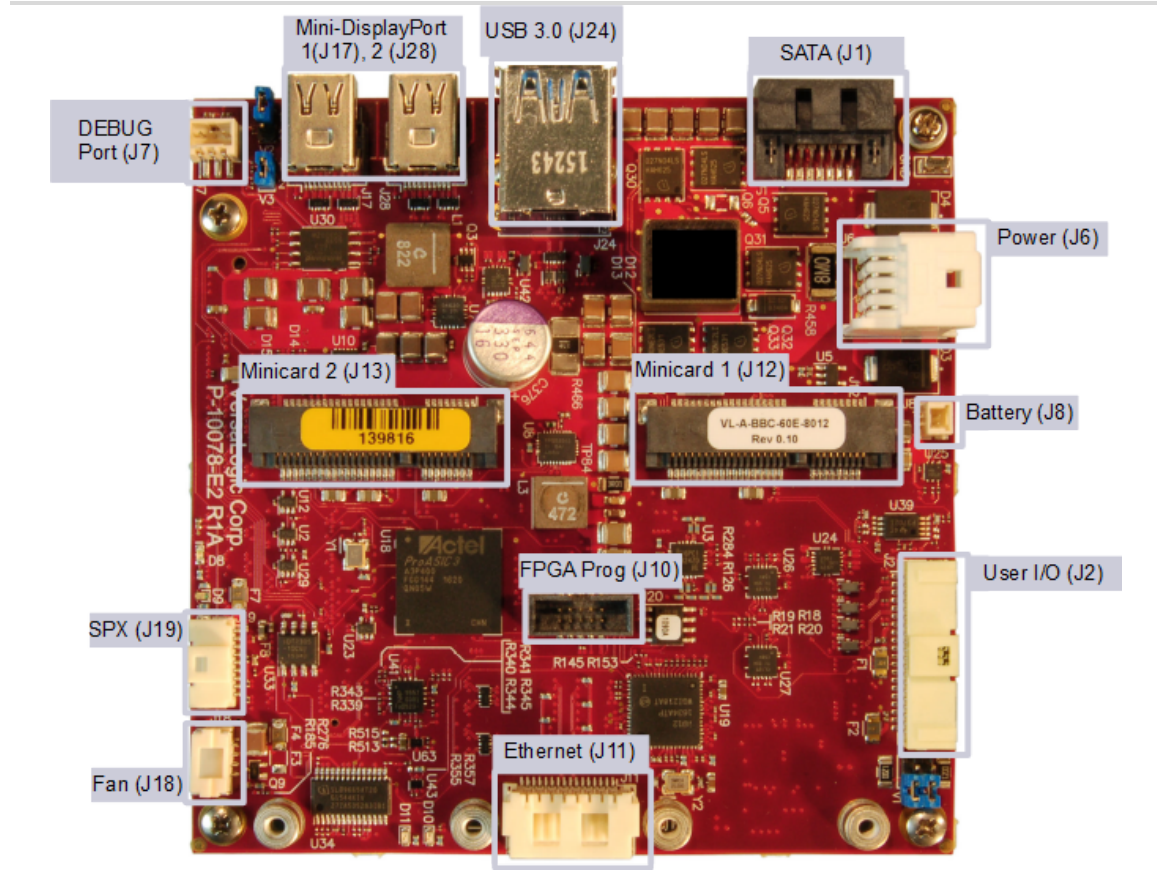

## Power Delivery

### Main Power Connector

An 8-pin power connector applies the Main input power to the Condor. The next figure shows the location and the pin orientation of the main power connector. Table 3 lists the pinout of the main power connector.

Figure 6. Main Power Connector Pin Orientation

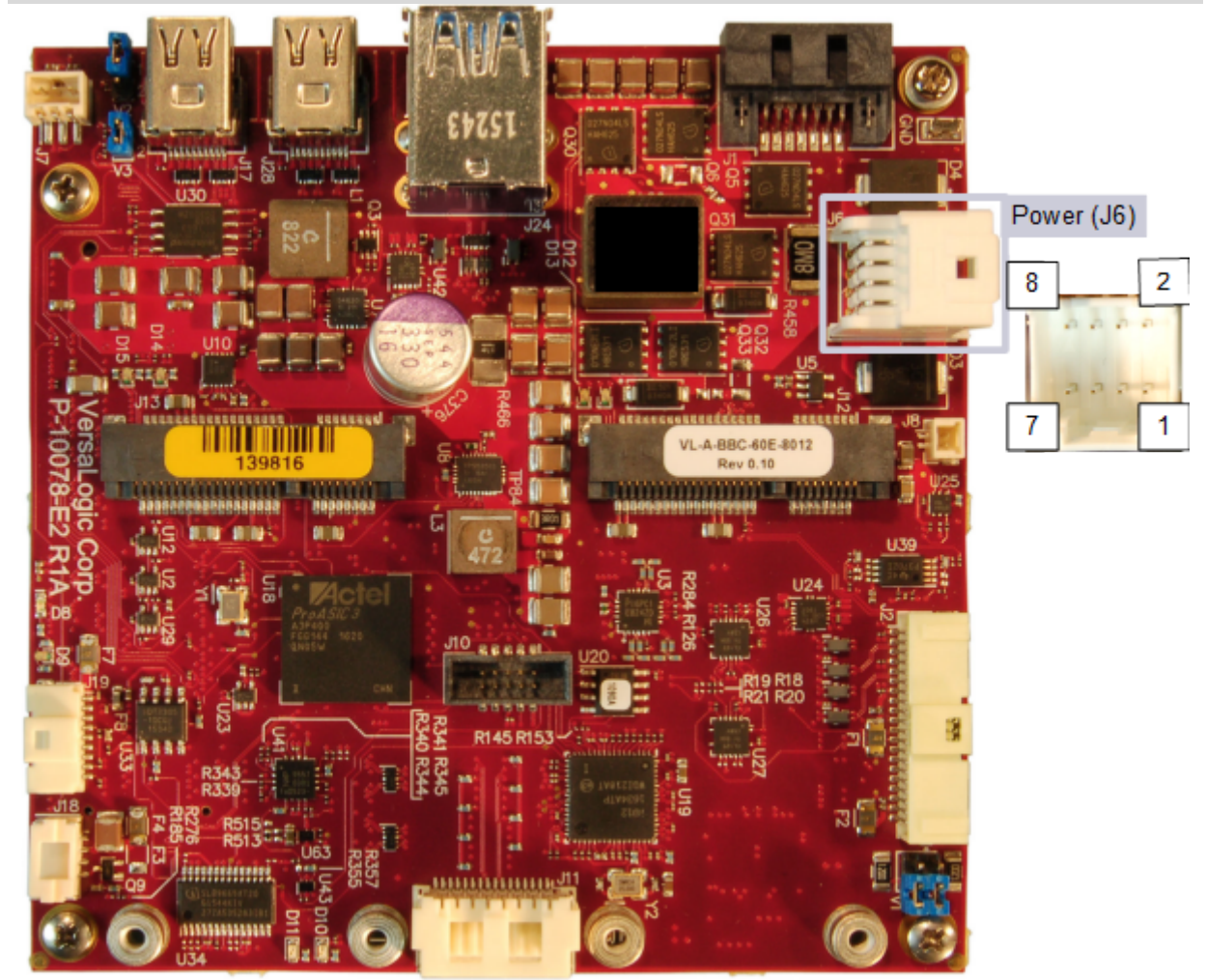

**Table 3. Main Power Connector Pinout**

Pin	Signal	Description	Pin	Signal	Description
1	PWRIN_POS	Main input voltage (+8V to +30V)	2	PWRIN_POS	Main input voltage (+8V to +30V)
3	EARTH_GND	Earth ground	4	PWRIN_POS	Main input voltage (+8V to +30V)
5	POWER_FAULT	An open-drain signal <ul style="list-style-type: none"> <li>Low if power is OK</li> <li>Open if there is a power fault (<b>Note</b>)</li> </ul>	6	PWRIN_NEG	Power return
7	PWRIN_NEG	Power return	8	PWRIN_NEG	Power return

**Note:** A power fault can be due any of the following conditions:

- The input power is off
- The main input regulator has failed
- The power input is under- or over-voltage (not in the 8 - 30V range)

### Cabling

An adapter cable, part number VL-CBR-0809, is available for connecting the Condor to an ATX power supply.

If your application requires a custom cable, the following information will be useful:

VL-EPU-4460 Board Connector	Mating Connector
Molex 055959-0830	Molex 051353-0800

### Power Requirements

The Condor requires a single +8 to +30 VDC supply capable of providing at least 35 W average power that can also provide a peak power of 50 W. The input DC supply creates both the standby and payload voltages provided to the CPU module.

The exact power requirements for the Condor depend on several factors, including CPU configuration (the number of cores, CPU clock rate), memory configuration, peripheral connections, and attached devices, and others. For example, driving long RS-232 lines at high speed can increase power demand.

The VersaLogic VL-PS-ATX12-300A is a 1U size ATX power supply suitable for use with the Condor. Use the VL-CBR-0809 adapter cable to attach the power supply to the main power connector.

### Power Delivery Considerations

Using the VersaLogic approved power supply (VL-PS-ATX12-300A) and power cable (VL-CBR-0809) will ensure high quality power delivery to the board. Customers who design their own power delivery methods should take into consideration the guidelines below to ensure good power connections.

The specifications for typical operating current do not include any off-board power usage that fed through the Condor power connector. Expansion boards and USB devices plugged into the board will source additional power through the Condor power connector.

- Do not use wire smaller than 22 AWG. Use high quality UL 1007 compliant stranded wire.
- The length of the wire should not exceed 18 inches.
- Avoid using any additional connectors in the power delivery system.
- The power and ground leads should be twisted together, or as close together as possible to reduce lead inductance.
- A separate conductor must be used for each of the power pins.
- All power input pins and all ground pins must be independently connected between the power source and the power connector.
- Use a high quality power supply that can supply a stable voltage while reacting to widely varying current draws.

### Power Button

The User I/O connector (shown in Figure 15 on page 32) includes an input for a power button. A momentary short to ground or assertion of pin 17 will cause a power button ACPI event. The button event can be configured in Windows to enter an S3 power state (Sleep, Standby, or Suspend-to-RAM), an S4 power state (Hibernate or Suspend-to-Disk), or an S5 power state (Shutdown or Soft-Off). This connector uses IEC 61000-4-2-rated TVS components to help protect against ESD damage.

A power button is provided on the VL-CBR-4005B paddleboard. Refer to the chapter titled VL-CBR-4005B Paddleboard, beginning on page 48 for more information.

### Supported Power States

This table lists the Condor's supported power states.

**Table 4. Supported Power States**

Power state	Description
S0 (G0)	Working
S1 (G1-S1)	All processor caches are flushed and the CPUs stop executing instructions. Power to the CPUs and RAM is maintained. Devices that do not indicate they must remain on may be powered down.
S3 (G1-S3)	Commonly referred to as Standby, Sleep, or Suspend-to-RAM. RAM remains powered.
S4 (G1-S4)	Hibernation or Suspend-to-Disk. All content of main memory is saved to non-volatile memory, such as a hard drive, and is powered down.
S5 (G2)	Soft Off. Almost the same as G3 Mechanical Off, except that the power supply still provides power, at a minimum, to the power button to allow return to S0. A full reboot is required. No previous content is retained. Other components may remain powered so the computer can "wake" on input from the keyboard, clock, modem, LAN, or USB device.
G3	Mechanical off (ATX supply switch turned off).

## Battery Power Options

The battery circuit on the Condor provides power for the Real-Time Clock (RTC) and power to store BIOS Setup utility settings in non-volatile RAM.

The Condor has multiple options for providing battery power:

- Use an external battery (the VL-CBR-0203, for example) connected to the board through the battery connector.
- Use the battery supplied with the CBR-4005B paddleboard

The figure below shows the location and pin orientation of the battery connector.

**Figure 7. Location and Pin Orientation of the Battery Connector**

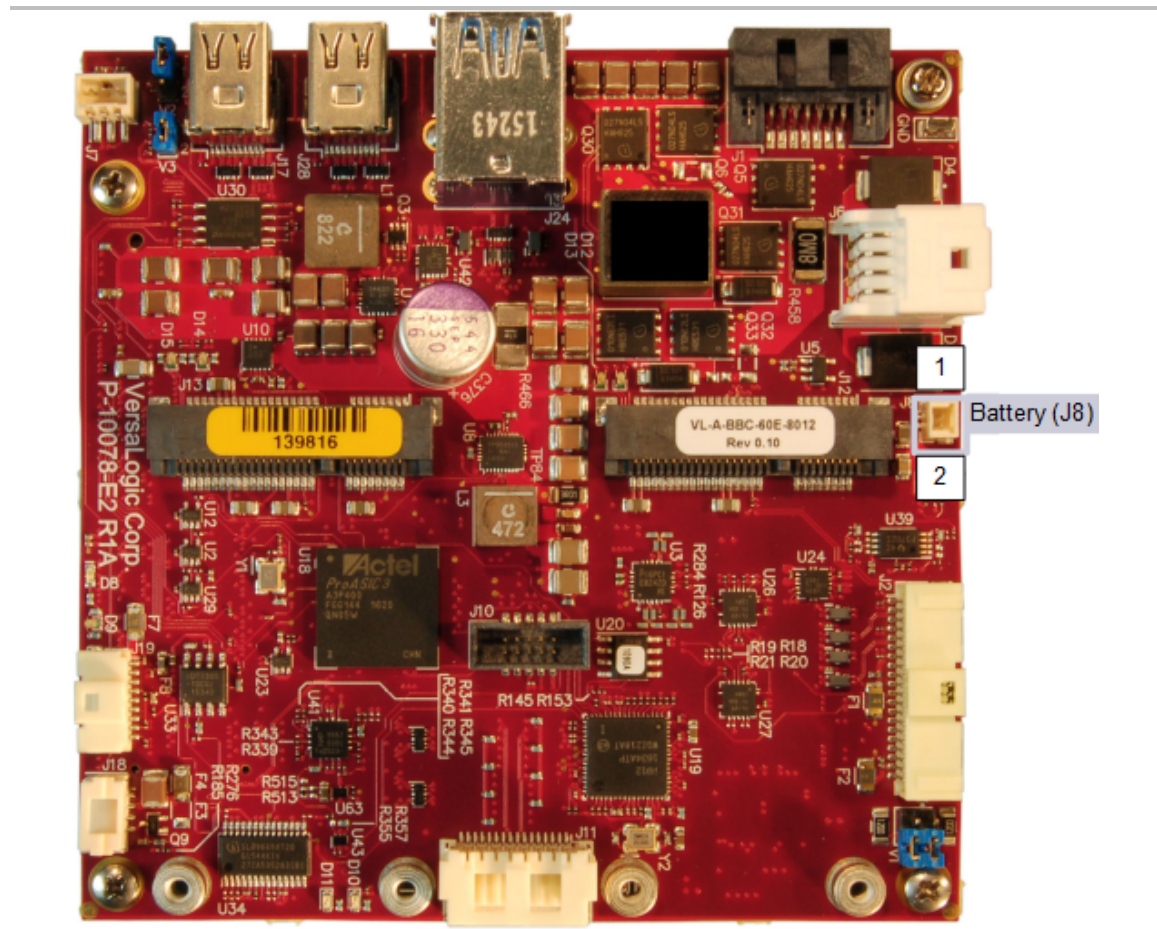

### Cabling

If your application requires a custom cable, the following information will be useful:

VL-EPU-4460 Board Connector	Mating Connector
Molex 501331-0207	Molex 501330-0200

### VL-CBR-0203 External Battery Module

The VL-CBR-0203 external battery module is compatible with the Condor. For more information, contact [Sales@VersaLogic.com](mailto:Sales@VersaLogic.com).

Figure 8. VL-CBR-0203 Latching Battery Module



### External Speaker

The User I/O connector (shown in Figure 15 on page 32) includes a speaker output signal at pin 15. The VL-CBR-4005B paddleboard provides a piezoelectric speaker. Figure 23 on page 48 shows the location of the piezoelectric speaker on the VL-CBR-4005B paddleboard.

### Push-button Reset

The User I/O connector (shown in Figure 15 on page 32) includes an input for a push-button reset switch. Shorting pin 18 to ground causes the Condor to reboot. This must be a mechanical switch or an open-collector or open-drain active switch with less than a 0.5V low-level input when the current is 1 mA. There must be no pull-up resistor on this signal. This connector uses IEC 61000-4-2-rated TVS components to help protect against ESD damage.

A reset button on the VL-CBR-4005B paddleboard is provided. Refer to the chapter titled VL-CBR-4005B Paddleboard, beginning on page 48 for more information.

## CPU Fan Connector

The Condor provides a four-pin CPU fan connector. The figure below shows the location and pin orientation of the CPU fan connector.

**Figure 9. Location and Pin Orientation of the CPU Fan Connector**

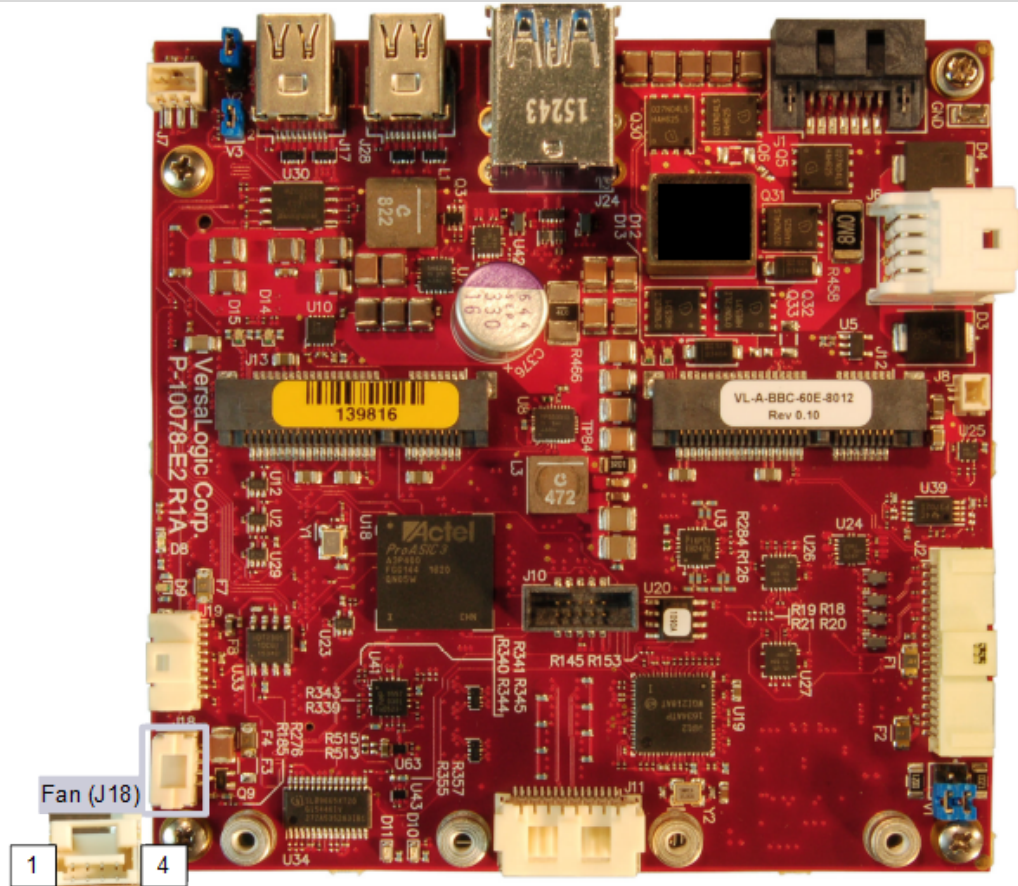

This table provides the pinout of the CPU fan connector.

**Table 5. CPU Fan Connector Pinout**

Pin	Signal
1	Ground
2	+12 VDC
3	FAN_TACH
4	FAN_CONTROL

## Cabling

If your application requires a custom cable, the following information will be useful:

<b>EPU-4460 Board Connector</b>	<b>Mating Connector</b>
Molex 502386-0470	Molex 502380-0400



## Mass Storage Interfaces

### SATA Interface

The Condor provides one serial ATA (SATA) port that communicates at a rate of up to 6.0 Gbits/s Both Standard (VL-CBR-0701) or Latching (VL-CBR-0702) cables are supported.

Figure 10. Location of the SATA Connector

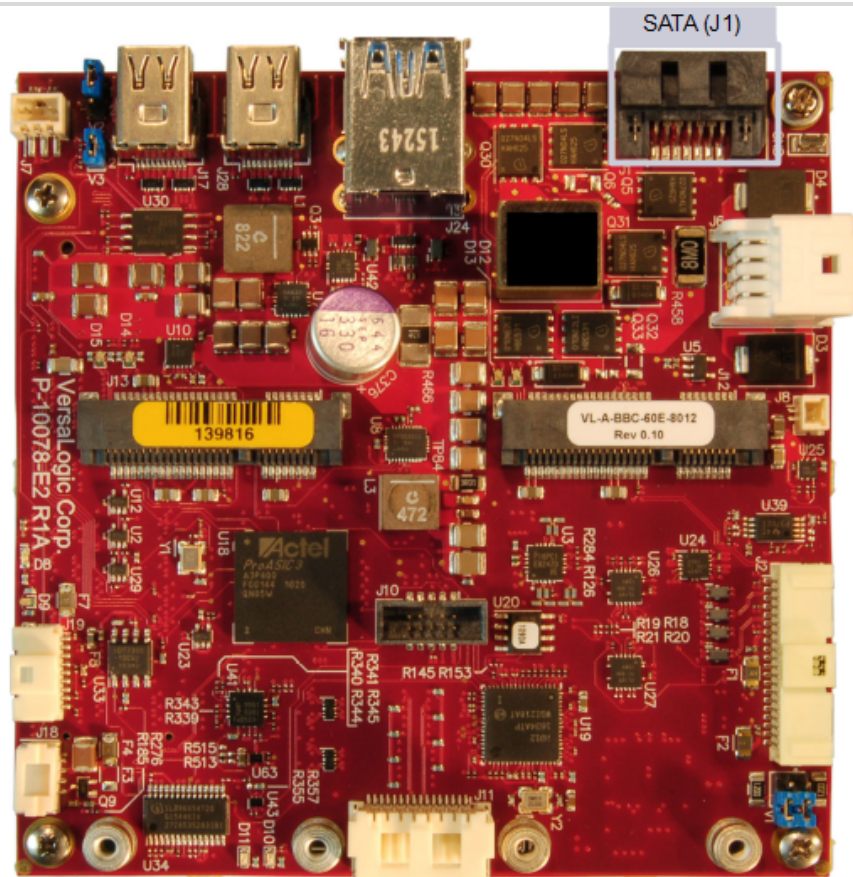

## USB Interfaces

As shown below, the Condor supports four USB 2.0 Host ports and two USB 3.0 Super-Speed ports.

Figure 11. Location of the USB Ports

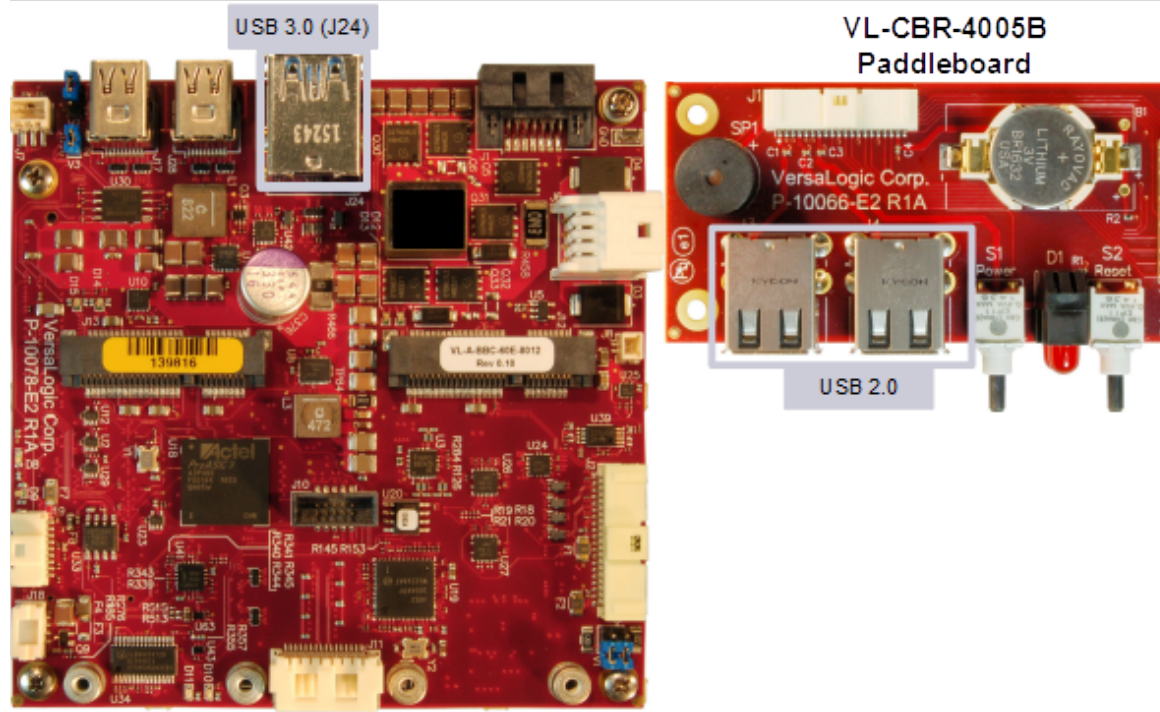

## Mini PCIe Sockets

The figure below shows the location of the two Mini PCIe sockets. Mini PCIe Socket #1 supports the use of an mSATA card.

Each Mini PCIe interface includes one PCIe x1 lane, one USB 2.0 channel, and the SMBus interface. The sockets are compatible with plug-in Wi-Fi modems, GPS receivers, MIL-STD-1553, flash data storage, and other cards for added flexibility. For information on Mini PCIe modules available from VersaLogic, contact [Sales@VersaLogic.com](mailto:Sales@VersaLogic.com).

The VL-MPEs-F1E series of mSATA modules provide flash storage of 4 GB, 16 GB, or 32 GB.

To secure a Mini PCIe card or mSATA module to the on-board standoffs, use two M2.5 x 6 mm pan head Philips nylon screws. These screws are available in quantities of 10 in the VL-HDW-108 hardware kit from VersaLogic.



### Integrator's Notes:

- Mini PCIe Socket #1 supports the use of an mSATA card; Socket #2 does not.

Figure 12. Location of Mini PCIe Sockets

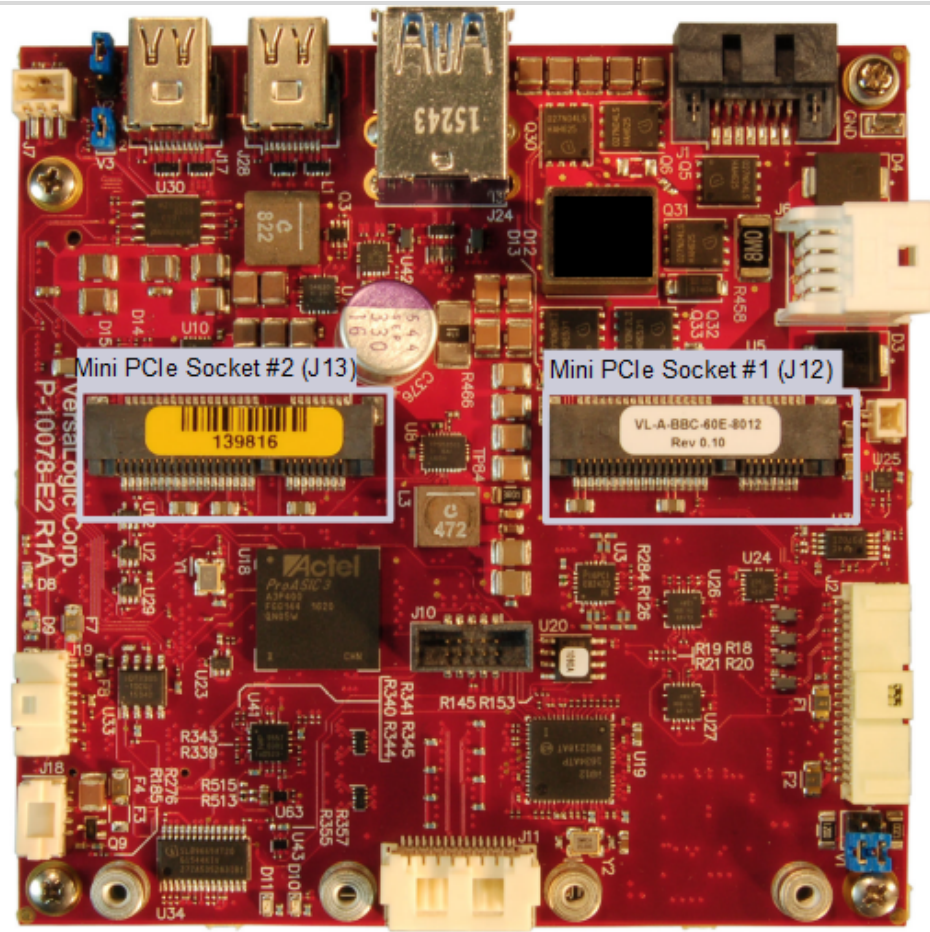

Table 6. Mini PCIe Socket 1 / mSATA Socket Pinout

Pin	Mini PCIe Signal Name	Mini PCIe Function	mSATA Signal Name (minicard 2)	mSATA Function (minicard 2)
1	WAKE#	Wake	Reserved	Not connected
2	3.3V	3.3 V	+3.3V	3.3 V source
3	NC	Not connected	Reserved	Not connected
4	GND	Ground	GND	Ground
5	NC	Not connected	Reserved	Not connected
6	1.5V	1.5 V power	+1.5V	1.5 V power
7	CLKREQ#	Reference clock request	Reserved	Not connected
8	NC	Not connected	Reserved	Not connected
9	GND	Ground	GND	Ground
10	NC	Not connected	Reserved	Not connected
11	REFCLK-	Reference clock input –	Reserved	Not connected
12	NC	Not connected	Reserved	Not connected
13	REFCLK+	Reference clock input +	Reserved	Not connected
14	NC	Not connected	Reserved	Not connected
15	GND	Ground	GND	Ground
16	NC	Not connected	Reserved	Not connected
17	NC	Not connected	Reserved	Not connected
18	GND	Ground	GND	Ground
19	NC	Not connected	Reserved	Not connected
20	W_DISABLE#	Wireless disable	Reserved	Not connected
21	GND	Ground	GND	Ground
22	PERST#	Card reset	Reserved	Not connected
23	PER0_N	PCIe receive –	SATA_RX_P	Host receiver diff. pair +
24	3.3V	3.3 V	+3.3V	3.3 V source
25	PER0_P	PCIe receive +	SATA_RX_N	Host receiver diff. pair –
26	GND	Ground	GND	Ground
27	GND	Ground	GND	Ground
28	1.5V	1.5 V power	+1.5V	1.5 V power
29	GND	Ground	GND	Ground
30	SMB_CLK	SMBus clock	Two Wire I/F	Two wire I/F clock
31	PET0_N	PCIe transmit –	SATA_TX_N	Host transmitter diff. pair –
32	SMB_DATA	SMBus data	Two Wire I/F	Two wire I/F data
33	PET0_P	PCIe transmit +	SATA_TX_P	Host transmitter diff. pair +
34	GND	Ground	GND	Ground
35	GND	Ground	GND	Ground

Pin	Mini PCIe Signal Name	Mini PCIe Function	mSATA Signal Name (minicard 2)	mSATA Function (minicard 2)
36	USB_N	USB data –	Reserved	Not connected
37	GND	Ground	GND	Ground
38	USB_P	USB data +	Reserved	Not connected
39	3.3V	3.3V	+3.3V	3.3 V source
40	GND	Ground	GND	Ground
41	3.3VAUX	3.3 V auxiliary source	+3.3V	3.3 V source
42	LED_WWAN#	Wireless WAN LED	Reserved	Not connected
43	GND	mSATA Detect ( <b>Note 1</b> )	GND/NC	Ground/Not connected ( <b>Note 2</b> )
44	LED_WLAN#	Wireless LAN LED	Reserved	Not connected
45	NC	Not connected	Vendor	Not connected
46	LED_WPAN#	Wireless PAN LED	Reserved	Not connected
47	NC	Not connected	Vendor	Not connected
48	1.5V	1.5 V power	+1.5V	1.5 V power
49	Reserved	Reserved	DA/DSS	Device activity ( <b>Note 3</b> )
50	GND	Ground	GND	Ground
51	Reserved	Reserved	GND	Ground ( <b>Note 4</b> )
52	3.3V	3.3 V	+3.3V	3.3 V source

**Notes:**

1. This pin is not grounded on the Condor on socket 1, since it can be used to detect the presence of an mSATA module versus a Mini PCIe card.
2. This pin is not grounded on the Condor to make it available for mSATA module detection.
3. This signal drives the blue LED activity indicator shown in Figure 14. This LED lights with mSATA disk activity (if supported by the mSATA module).
4. Some Mini PCIe cards use this signal as a second Mini PCIe card wireless disable input. On the Condor, this signal is available for use for mSATA versus Mini PCIe card detection. There is an option on the VersaLogic Features BIOS Setup utility screen for setting the mSATA detection method.

**W\_DISABLE# Signal**

The W\_DISABLE# signal is for use with optional wireless Ethernet Mini PCIe cards. The signal enables you to disable a wireless card's radio operation in order to meet public safety regulations or when otherwise desired. W\_DISABLE# is an active low signal that when driven low (shorted to ground) disables radio operation on the Mini PCIe card wireless device. When W\_DISABLE# is not asserted, or in a high impedance state, the radio may transmit if not disabled by other means such as software. The W\_DISABLE# signals for each of the two Minicards are controlled by registers in the FPGA.

### Mini PCIe Card Wireless Status LEDs

Dual-colored (green and yellow) LEDs provide status for modules installed in the Mini PCIe sockets. These LEDs light when the associated device is installed and capable of transmitting. The table below lists the states of the LEDs. The figure below shows the locations on the Condor.

**Table 7. Mini PCIe Card Wireless Status LEDs**

LED	Color	State	Description
D12 (minicard 1) and D14 (minicard 2)	Green	On <span style="color: green;">■</span>	Wireless WAN active
		Off <span style="color: blue;">▬</span>	Wireless WAN inactive
	Yellow	On <span style="color: yellow;">■</span>	Wireless LAN active
		Off <span style="color: blue;">▬</span>	Wireless LAN inactive
D13 (minicard 1) and D15 (minicard 2)	Green	On <span style="color: green;">■</span>	Wireless PAN active
		Off <span style="color: blue;">▬</span>	Wireless PAN inactive
	Yellow	On <span style="color: yellow;">■</span>	Minicard power is ON
		Off <span style="color: blue;">▬</span>	Minicard power is OFF

**Figure 13. Mini PCIe Wireless Status LEDs**

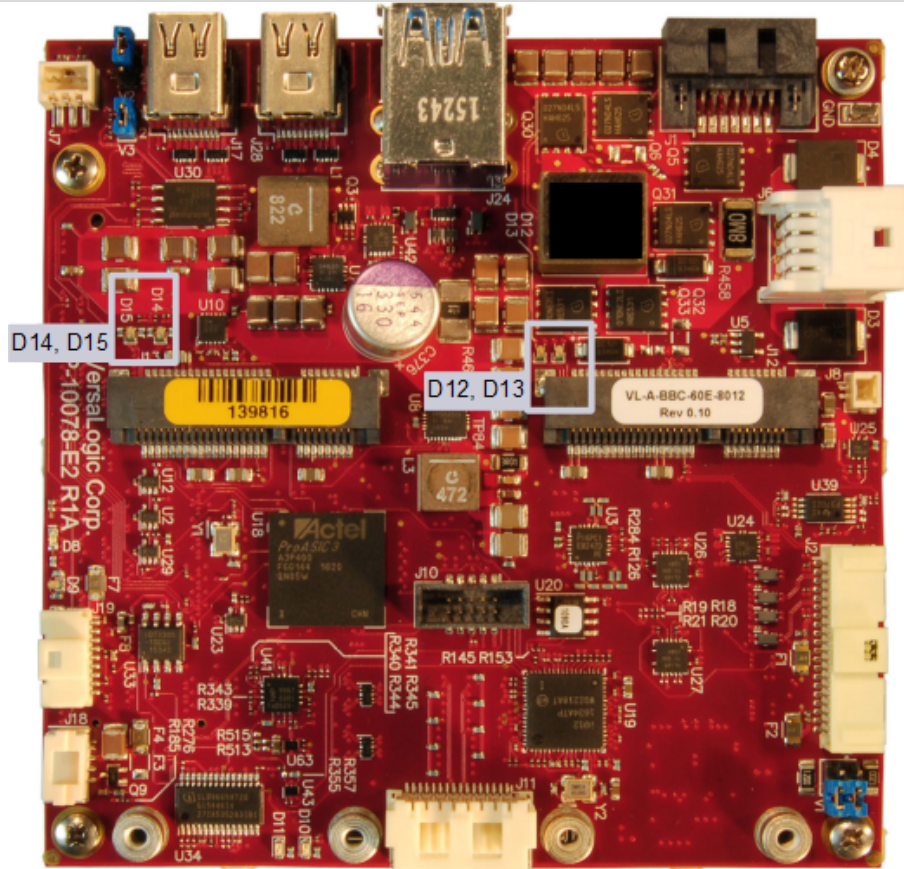

## SATA Activity LED

The figure below shows the location of the SATA/mSATA activity blue LED. This LED indicates activity on either the SATA or the mSATA interface. Not all mSATA drives provide this disk activity signal.

**Figure 14. Location of the SATA/mSATA Activity LED**

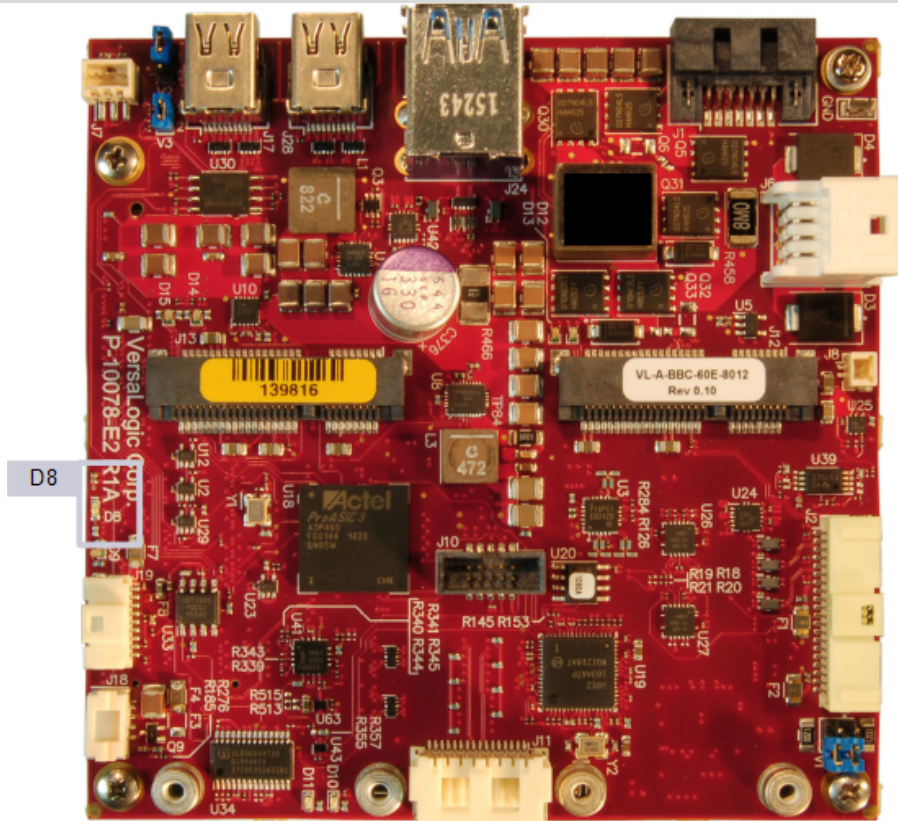

## User I/O Connector

The 40-pin user I/O connector incorporates the signals for the following:

- Four USB ports
- Eight GPIO lines (these are functionally muxed with six timer I/O signals per FPGA registers). There are eight timer signals and they share digital I/Os 16-9. The eight GPIO lines on the paddleboard each have an alternate mode, accessible using the FPGA's AUXMOD1 register. Refer to the *EPU-4460 Programmer's Reference Manual* for more information on FPGA registers.
- Three LEDs (two Ethernet link/status LEDs and a programmable LED)
- Two I<sup>2</sup>C signals (clock and data)
- Push-button power switch
- Push-button reset switch
- Speaker output

This connector uses IEC 61000-4-2-rated TVS components to help protect against ESD damage.

The figure below shows the location and pin orientation of the user I/O connector.

**Figure 15. Location and Pin Orientation of the User I/O Connector**

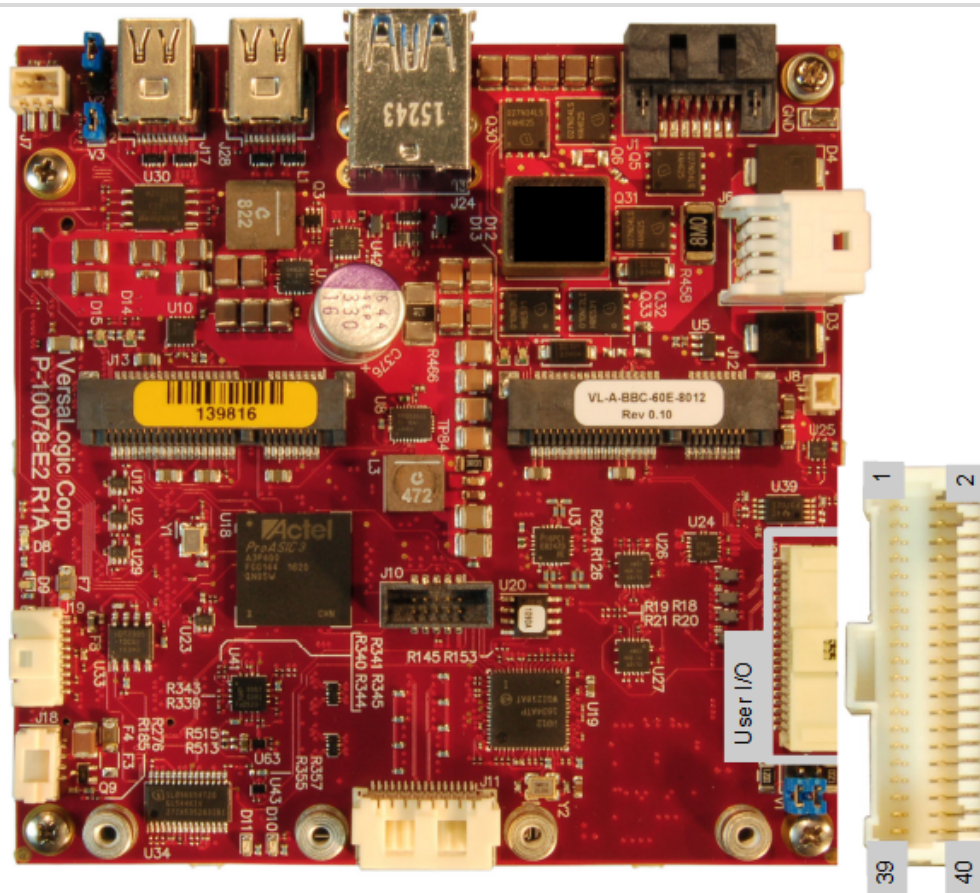



The table below provides the pinout of the user I/O connector.

**Table 8. User I/O Connector Pinout and Pin Orientation**

Pin	Signal	Pin	Signal
1	V5_USB1-2 (Note 1)	2	GND
3	USB1_P	4	USB2_P
5	USB1_N	6	USB2_N
7	V5_USB3-4 (Note 2)	8	GND
9	USB3_P	10	USB4_P
11	USB3_N	12	USB4_N
13	V3P3_S0 (Note 3)	14	GND
15	SPKR#	16	PLED#
17	PWR_BTN#	18	RST_BTN#
19	GND	20	GND
21	I2C_SCK	22	V_BATT
23	I2C_SDA	24	V_BATT Return
25	GND	26	GND
27	GPIO1	28	GPIO2
29	GPIO3	30	GPIO4
31	GND	32	GND
33	GPIO5	34	GPIO6
35	GPIO7	36	GPIO8
37	V3P3_SX (Note 4)	38	GND
39	ETH_LED1	40	ETH_LED2

**Notes:**

1. This is the +5V VBUS power for USB Port 1 and 2.
2. This is the +5V VBUS power for USB Port 3 and 4.
3. This 3.3 V power goes off in sleep modes. The SPKR# uses this power as should the PLED# (there is no requirement for PLED# to use this power, but the VL-CBR-4005B paddleboard does).
4. This 3.3 V power can be turned on or off similar to the 3.3V power to the Mini Card via the FPGA (can go off in sleep modes or always stay on; by default it goes off in sleep modes). It is used for the 10 k $\Omega$  pullup resistor power on the 8x GPIOs and usually for the 2x Ethernet LEDs, however, the Ethernet LEDs can be powered by a 3.3 V power source.

## Cabling

An adapter cable, part number VL-CBR-4005A, is available for connecting the CBR-4005B paddleboard to the VL-EPU-4460. This is a 12-inch, Pico-Clasp 40-pin to 40-pin cable.

If your application requires a custom cable, the following information will be useful:

EPU-4460 Board Connector	Mating Connector
Molex 501571-4007	Molex 501189-4010

## SPX\* Expansion Bus

Up to two serial peripheral expansion (SPX) devices can be attached to the Condor at connector using a CBR-0901 cable. The SPX interface provides the standard serial peripheral interface (SPI) signals: CLK, MISO, and MOSI, as well as two chip selects, SS0# and SS1#. The +5 V power provided to pin 1 of the SPX connector is protected by a 1 A resettable fuse.

The figure below shows the location and pin orientation of the SPX connector.

**Figure 16. SPX Connector Location and Pin Configuration**

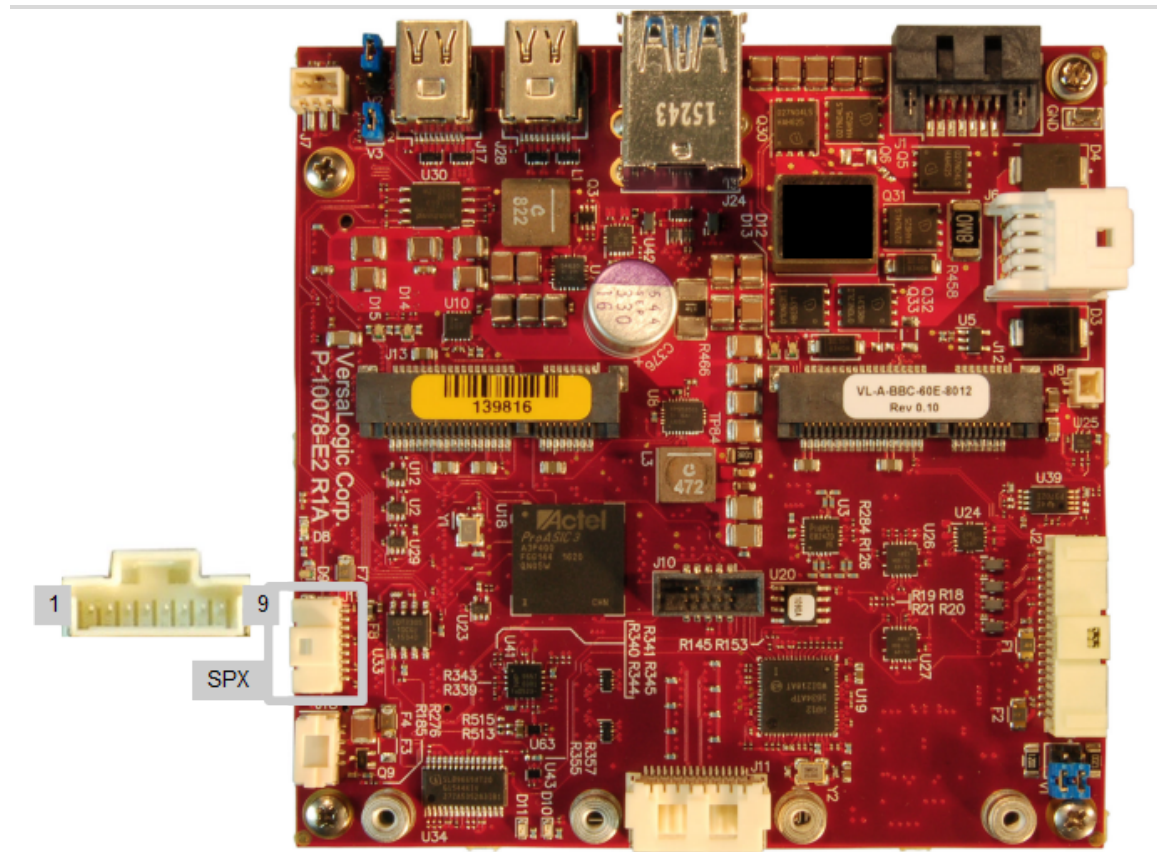

The table below lists the pinout of the SPX connector.

**Table 9. SPX Connector Pinout**

Pin	Signal	Function
1	VCC	+5.0 V
2	SCLK	SPX Clock
3	GND	Ground
4	MISO	Master input, Slave output
5	GND	Ground
6	MOSI	Master output, Slave input
7	GND	Ground
8	SS0#	Chip Select 0
9	SS1#	Chip Select 1

SPI is, in its simplest form, a three wire serial bus. One signal is a clock, driven only by the permanent master device on-board. The others are Data In and Data Out with respect to the master. The SPX implementation on the Condor supports chip selects. The master device initiates all SPI transactions. A slave device responds when its chip select is asserted and it receives clock pulses from the master. All four common SPI modes are supported through the use of clock polarity and clock idle state controls.

The SPI clock is derived from a 24 MHz PCI clock and can be software-configured to operate at the following frequencies:

- 6 MHz (24 MHz/4)
- 3 MHz (24MHz/8)
- 1.5 MHz (24MHz/16)
- 0.75 MHz (24MHz/32)

### Cabling

An adapter cable, part number CBR-0901, is available. This is a 9-inch, 9-pin Pico-Clasp to Dual SPX cable.

If your application requires a custom cable, the following information will be useful:

EPU-4460 Board Connector	Mating Connector
Molex 501568-0907	Molex 501330-0900

## Serial Ports

The Condor provides two serial ports. Both ports can be operated in RS-232, RS-422, or RS-485 mode. IRQ lines are chosen in the BIOS Setup utility. The UARTs are 16550-based serial ports and are implemented in the FPGA.

The next figure shows the location and pin orientation of the two serial I/O connectors.

**Figure 17. Location and Pin Orientation of the Serial I/O Connectors**

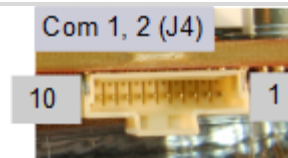

## Serial Port Connector Pinout

Table 10. COM1/COM2 Connector Pinout

Pin	RS-232 Signal	RS-422/RS-485 Signal	Port
1	RTS1	TXD1_P	COM1
2	TXD1#	TXD1_N	
3	CTS1	RXD1_P	
4	RXD1#	RXD1_N	
5	GND	GND	—
6	RTS2	TXD2_P	COM2
7	TXD2#	TXD2_N	
8	CTS2	RXD2_P	
9	RXD2#	RXD2_N	
10	GND	GND	—

## Cabling

An adapter cable, part number CBR-1014, is available for routing the serial I/O signals to 9-pin D-sub connectors. This is a 12-inch, Pico-Clasp 10-pin to two 9-pin D-sub connector cable.

If your application requires a custom cable, the following information will be useful:

EPU-4460 Board Connector	Mating Connector
Molex 501331-1007	Molex 501330-1000

## COM Port Configuration

Jumper block V1 configures the serial ports for RS-485/RS-422 operation. See the section titled “Jumper Blocks” on page 15 for details. The termination resistor should only be enabled for RS-485 or RS-422 endpoint stations and not for intermediate stations. Termination must not be used for RS-232.

## Console Redirection

The Condor can be configured for remote access by redirecting the console to a serial communications port. The BIOS Setup utility and some operating systems (such as MS-DOS) can use this console for user interaction. The default settings for the redirected console are as follows:

- 115,200 baud rate
- 8 data bits, No parity, 1 stop bit (that is, 8-None-1)
- No flow control

The Intel Core\* 6xxx processor series contains an integrated graphics engine with advanced 2D/3D graphics, video decode and encode capabilities, and a display controller. The Condor provides the following video interfaces:

- Two Mini DisplayPort++ connectors
- Dual LVDS display connectors; a 4-pin LVDS backlight connector is also provided

## Mini DisplayPort++ Connectors

DisplayPort consists of three interfaces:

- Main Link – transfers high-speed isochronous video and audio data
- Auxiliary channel – used for link management and device control; the EDID is read over this interface
- Hot Plug Detect – indicates that a cable is plugged in

The DisplayPort interface supports:

- Audio signaling
- DP++ mode allowing connection to an HDMI device through a passive adapter. “Passive” means and it does not require software drivers or do protocol conversion.

The next figure shows the location of the 20-pin Mini DisplayPort++ connector. Table 11 lists the pinout of the Mini DisplayPort++ connector.

Figure 18. Location of the Mini DisplayPort++ Connectors

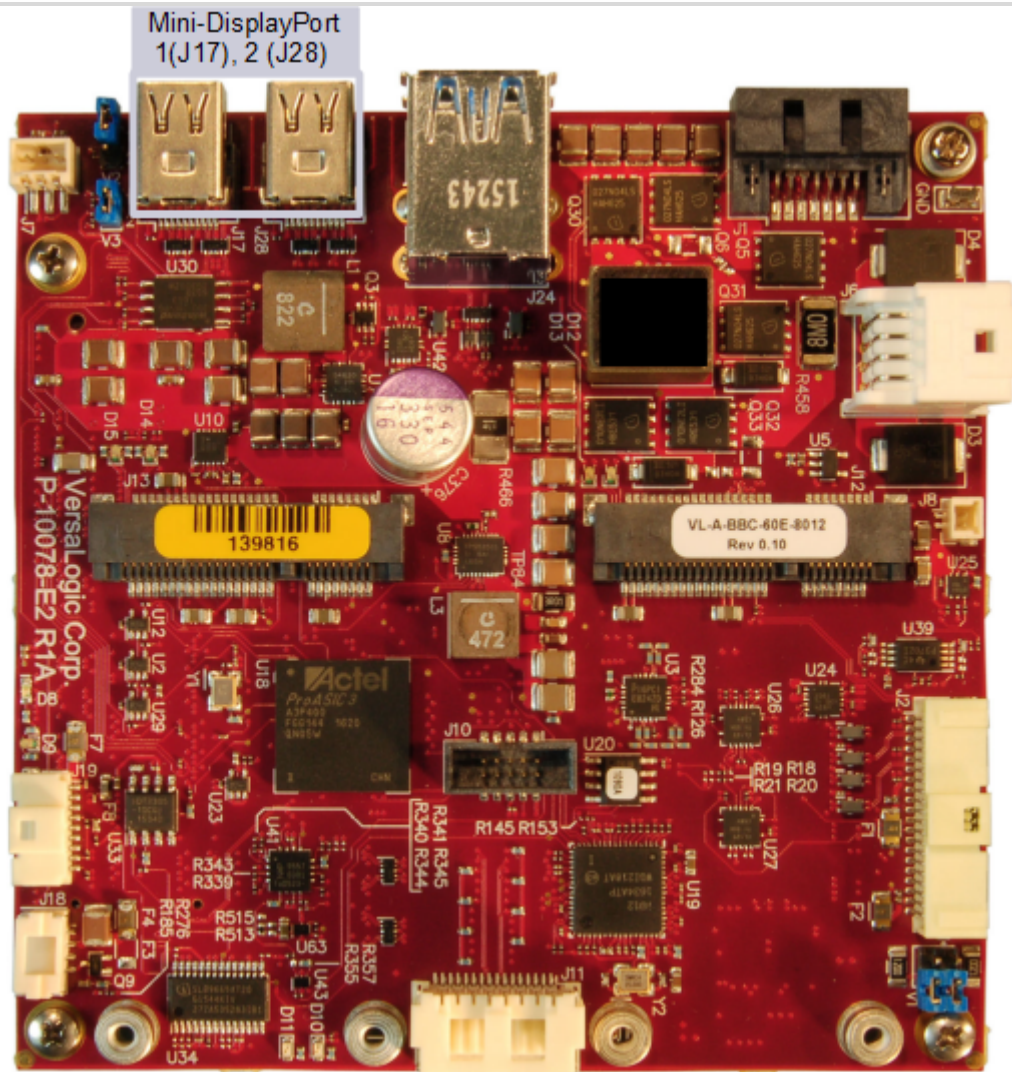

Table 11. Mini DisplayPort++ Connector Pinout

Pin	Signal	Pin	Signal
1	GND	2	HOT PLUG DETECT
3	ML_LANE0_P	4	CONFIG 1
5	ML_LANE0_N	6	CONFIG 2
7	GND	8	GND
9	ML_LANE1_P	10	ML_LANE3_P
11	ML_LANE1_N	12	ML_LANE3_N
13	GND	14	GND
15	ML_LANE2_P	16	AUX_CH_P
17	ML_LANE2_N	18	AUX_CH_N
19	GND	20	DP_POWER (3.3V)

### VGA Output

A VGA monitor can be attached to the Mini DisplayPort++ connector using the VL-CBR-2032 Mini DisplayPort-to-VGA adapter, similar to the one shown in the following figure.

**Figure 19. VL-CBR-2032 Mini DisplayPort to VGA Adapter**

---





## LVDS Interface

### LVDS Flat Panel Display Connectors

The condor supports a full 24-bit Dual-LVDS panel interface. A 30-pin right-angle top-mount connector VL P/N XPM1R30ST1 is used for this. 3.3V panel power is also supported and can be switched on using the COM Module LVDS\_VDDEN signal. Overcurrent status on this switch can be read via the FPGA.

A COM Module supports LVDS backlight. The backlight enable and backlight control signals are connected to a 4-pin pico-clasp connector VL P/N X1S1R04SL

The BIOS Setup utility provides several options for standard LVDS flat panel types. If these options do not match the requirements of the panel you are using, contact [Support@VersaLogic.com](mailto:Support@VersaLogic.com) for a custom video BIOS.

**Figure 20. Location of the LVDS Connectors**



**Table 12. LVDS Flat Panel Display Connector Pinout**

Pin	Signal Name	Function
1	GD1	Guard (tie to Earth Ground).
2	LVDS_ODD0_N	LVDS Odd Lane 0 Neg Diff Signal
3	LVDS_ODD0_P	LVDS Odd Lane 0 Pos Diff Signal
4	LVDS_ODD1_N	LVDS Odd Lane 1 Neg Diff Signal
5	LVDS_ODD1_P	LVDS Odd Lane 1 Pos Diff Signal
6	LVDS_ODD2_N	LVDS Odd Lane 2 Neg Diff Signal
7	LVDS_ODD2_P	LVDS Odd Lane 2 Pos Diff Signal
8	GND1	Signal/Power Ground
9	LVDS_ODDCLK_N	LVDS Odd Clock Neg Diff Signal
10	LVDS_ODDCLK_P	LVDS Odd Clock Pos Diff Signal
11	LVDS_ODD3_N	LVDS Odd Lane 3 Neg Diff Signal
12	LVDS_ODD3_P	LVDS Odd Lane 3 Pos Diff Signal
13	LVDS_EVEN0_N	LVDS Even Lane 0 Neg Diff Signal
14	LVDS_EVEN0_P	LVDS Even Lane 0 Pos Diff Signal
15	GND2	Signal/Power Ground
16	LVDS_EVEN1_N	LVDS Even Lane 1 Neg Diff Signal
17	LVDS_EVEN1_P	LVDS Even Lane 1 Pos Diff Signal
18	GND3	Signal/Power Ground
19	LVDS_EVEN2_N	LVDS Even Lane 2 Neg Diff Signal
20	LVDS_EVEN2_P	LVDS Even Lane 2 Pos Diff Signal
21	LVDS_EVENCLK_N	LVDS Even Clock Neg Diff Signal
22	LVDS_EVENCLK_P	LVDS Even Clock Pos Diff Signal
23	LVDS_EVEN3_N	LVDS Even Lane 3 Neg Diff Signal
24	LVDS_EVEN3_P	LVDS Even Lane 3 Pos Diff Signal
25	GND4	Signal/Power Ground
26	GND5	Signal/Power Ground
27	VCC1	Panel Power (3.3V)
28	GND6	Signal/Power Ground
29	VCC2	Panel Power (3.3V)
30	VCC3	Panel Power (3.3V)
31	VCC4	Panel Power (3.3V)
32	GD2	Guard (tie to Earth Ground).

**Cabling**

The following LVDS cables are available for use with the Condor board:

- VL-CBR-3001 – a 20-inch 2-Ch LVDS 30-pin JAE to 30-pin JAE
- VL-CBR-3002 – a 20-inch 1-Ch LVDS 30-pin JAE to 1.25mm 20-pin Hirose
- VL-CBR-3003 – a 20-inch 1-Ch LVDS 30-pin JAE to 20-pin JAE

If your application requires a custom cable, the following information will be useful:

<b>EPU-4460 Board Connector</b>	<b>Mating Connector</b>
Hirose DF19G-20P-1H(54)	<ul style="list-style-type: none"><li data-bbox="776 289 1175 321">• Hirose DF19G-20S-1C (housing)</li><li data-bbox="776 325 1289 357">• Hirose DF19-2830SCFA x19 (crimp socket)</li></ul>

## LVDS Backlight Connector

Figure 20 on page 41 shows the location and pin orientation of the LVDS back light connector. The next table lists the pinout of the LVDS backlight connector.

**Table 13. LVDS Backlight Connector Pinout**

Pin	Signal Name	Function
1	LVDS_BKLT_EN	LVDS backlight enable output. (5V TTL-level signal by default but will operate at higher voltages if the LVDS_BKLT_PWR is provided). High = enabled, Low = disabled.
2	Signal Ground	Ground
3	LVDS_BKLT_CTRL	LVDS backlight control output. (5V TTL-level signal by default but will operate at higher voltages if the LVDS_BKLT_PWR is provided). This is a PWM signal and the duty cycle can be set in the BIOS Setup utility.
4	LVDS_BKLT_LOGIC_PWR	Optional backlight logic power input. (Can range from +5V to +14V and sets the high-value on the LVDS_BKLT_EN and LVDS_BKLT_CTRL signals.) On-board +5V power is used when this is not connected.

### Cabling

An adapter cable, part number CBR-0404, is available for powering the LVDS backlight from the Condor board.

If your application requires a custom cable, the following information will be useful:

EPU-4460 Board Connector	Mating Connector
Molex 501568-0407	Molex 501330-0400

## Network Interfaces

The Condor provides two Gigabit Ethernet controllers (Intel I210-IT and Intel I219-LM). The controllers provide a standard IEEE 802.3 Ethernet interface for 1000Base-T, 100Base-TX, and 10Base-T applications. The I210-IT Ethernet controller auto-negotiates connection speed. Drivers are readily available to support a variety of operating systems. For more information on this device, refer to the [Intel I210 Ethernet Controller datasheet](#).

**✖ Integrator's Note:** Ethernet Port 1 supports network boot; Port 0 does not.

### Ethernet Connector

The Ethernet connector provides access to the Ethernet ports 0 and 1. The connector uses IEC 61000-4-2-rated TVS components to help protect against ESD damage. The figure below shows the location and pin orientation of the Ethernet connector.

**Figure 21. Location and Pin Orientation of the Ethernet Connector**

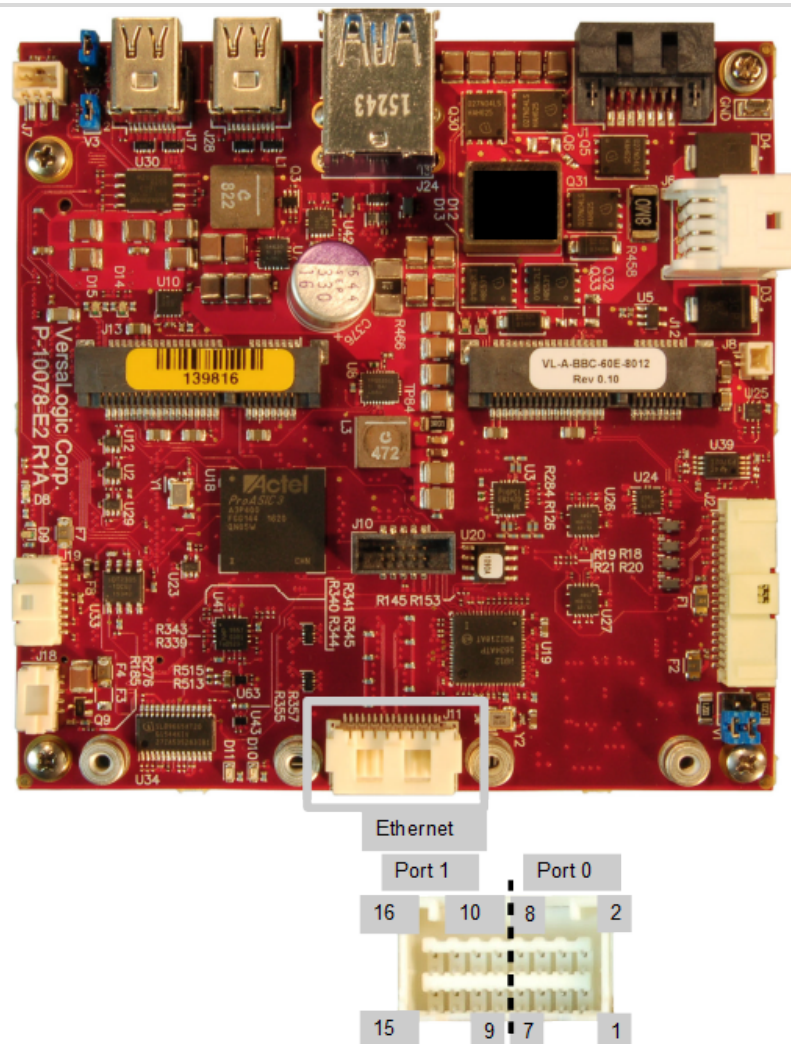

The next table lists the pinout of the Ethernet connector.

**Table 14. Ethernet Connector Pinout**

	Pin	10/100 Signals	10/100/1000 Signals		Pin	10/100 Signals	10/100/1000 Signals	
<b>Port 0</b>	1	- Auto Switch (Tx or Rx)	BI_DD-	<b>Port 0</b>	2	+ Auto Switch (Tx or Rx)	BI_DD+	
	3	- Auto Switch (Tx or Rx)	BI_DB-		4	+ Auto Switch (Tx or Rx)	BI_DB+	
	5	- Auto Switch (Tx or Rx)	BI_DC-		6	+ Auto Switch (Tx or Rx)	BI_DC+	
	7	- Auto Switch (Tx or Rx)	BI_DA-		8	+ Auto Switch (Tx or Rx)	BI_DA+	
<b>Port 1</b>	9	- Auto Switch (Tx or Rx)	BI_DD-	<b>Port 1</b>	10	+ Auto Switch (Tx or Rx)	BI_DD+	
	11	- Auto Switch (Tx or Rx)	BI_DB-		12	+ Auto Switch (Tx or Rx)	BI_DB+	
	13	- Auto Switch (Tx or Rx)	BI_DC-		14	+ Auto Switch (Tx or Rx)	BI_DC+	
	15	- Auto Switch (Tx or Rx)	BI_DA-		16	+ Auto Switch (Tx or Rx)	BI_DA+	

### Cabling

An adapter cable, part number CBR-1604, is available. This is a 12-inch, 16-pin Click-Mate to two RJ-45 connector cables.

If your application requires a custom cable, the following information will be useful:

<b>EPU-4460 Board Connector</b>	<b>Mating Connector</b>
Molex 503148-1690	Molex 503149-1600



## VL-CBR-4005B Paddleboard

### VL-CBR-4005B Connectors and Indicators

The next figure shows the locations of the connectors, switches, and LEDs on the VL-CBR-4005B paddleboard.

Figure 23. VL-CBR-4005B Connectors, Switches, and LEDs

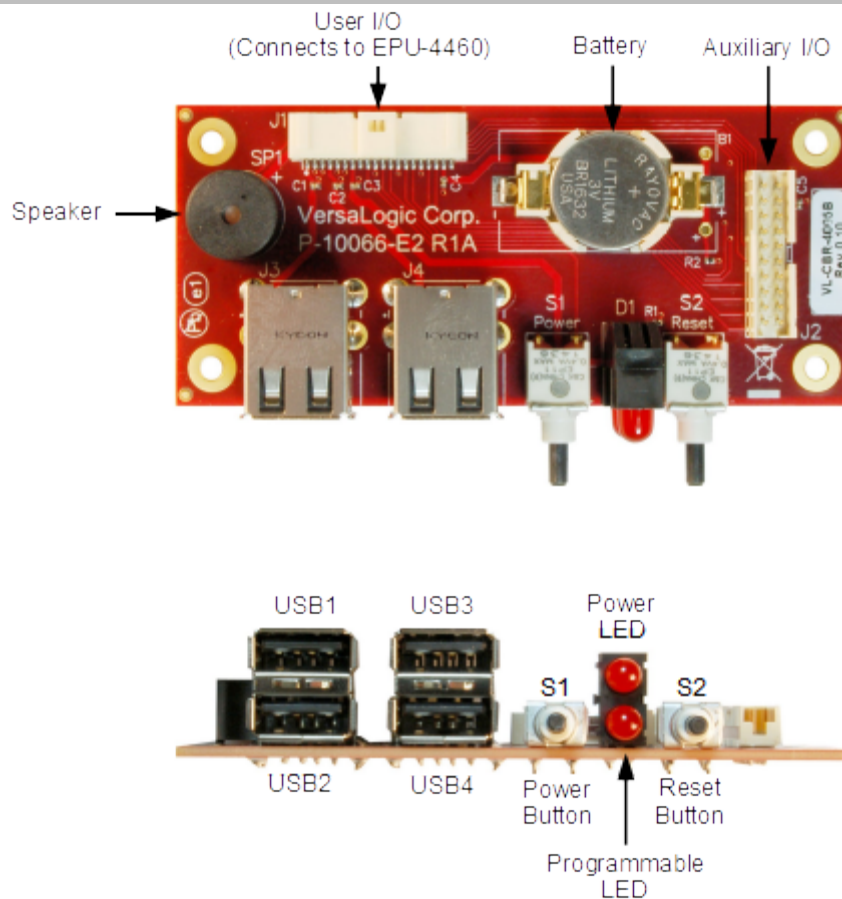



## User I/O Connector

The following figure shows the location and pin orientation of the user I/O connector.

Figure 24. Location and Pin Orientation of the User I/O Connector

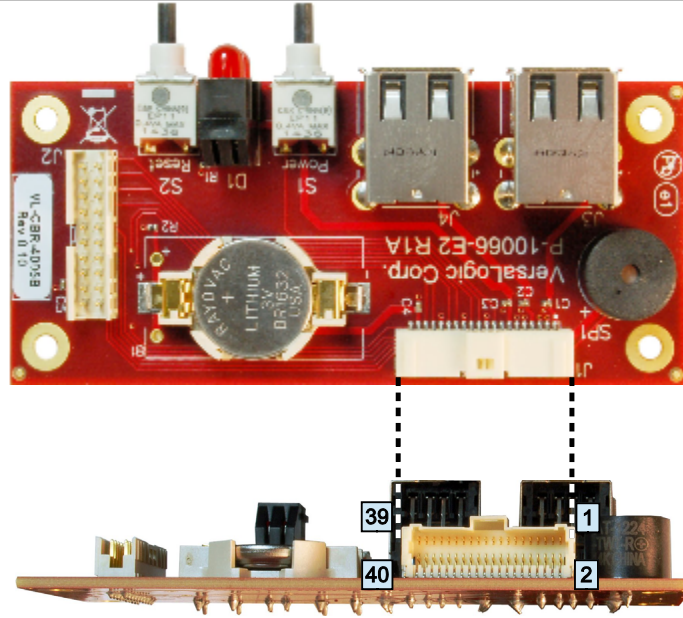

Table 15. User I/O Connector Pinout

Pin	Signal	Pin	Signal
1	V5_USB1-2 (Note 1)	2	GND
3	USB1_P	4	USB2_P
5	USB1_N	6	USB2_N
7	V5_USB3-4 (Note 2)	8	GND
9	USB3_P	10	USB4_P
11	USB3_N	12	USB4_N
13	V3P3_S0 (Note 3)	14	GND
15	SPKR#	16	PLED#
17	PWR_BTN#	18	RST_BTN#
19	GND	20	GND
21	I2C_SCK	22	V_BATT
23	I2C_SDA	24	V_BATT Return
25	GND	26	GND
27	GPIO1	28	GPIO2
29	GPIO3	30	GPIO4
31	GND	32	GND
33	GPIO5	34	GPIO6
35	GPIO7	36	GPIO8
37	V3P3_SX (Note 4)	38	GND
39	ETH_LED1	40	ETH_LED2

**Notes:**

1. This is the +5V VBUS power for USB Port 1 and 2.
2. This is the +5V VBUS power for USB Port 3 and 4.
3. This 3.3 V power goes off in sleep modes. The SPKR# uses this power as should the PLED# (there is no requirement for PLED# to use this power, but the VL-CBR-4005B paddleboard does).
4. This 3.3 V power can be turned on or off similar to the 3.3V power to the Mini Card via the FPGA (can go off in sleep modes or always stay on; by default it goes off in sleep modes). It is used for the 10 k $\Omega$  pullup resistor power on the 8x GPIOs and usually for the 2x Ethernet LEDs, however, the Ethernet LEDs can be powered by a 3.3 V power source.

**Cabling**

An adapter cable, part number CBR-4005A, is available for connecting the VL-CBR-4005B paddleboard to the EPU-4460. This is a 12-inch, Pico-Clasp 40-pin to 40-pin cable

If your application requires a custom cable, the following information will be useful:

CBR-4005B Board Connector	Mating Connector
Molex 501571-4007	Molex 501189-4010

**On-board Battery****CAUTION:**

To prevent shorting, premature failure or damage to the Lithium battery, do not place the board on a conductive surface such as metal, black conductive foam or the outside surface of a metalized ESD protective pouch. The Lithium battery may explode if mistreated. Do not recharge, disassemble, or dispose of the battery in fire. Dispose of used batteries promptly.

Nominal battery voltage is 3.0 V. If the voltage drops below 2.7 V, contact the factory for a replacement. The life expectancy under normal use is approximately five years.

## Auxiliary I/O Connector

This figure shows the location and pin orientation of the auxiliary I/O connector.

Figure 25. Location and Pin Orientation of Auxiliary I/O Connector

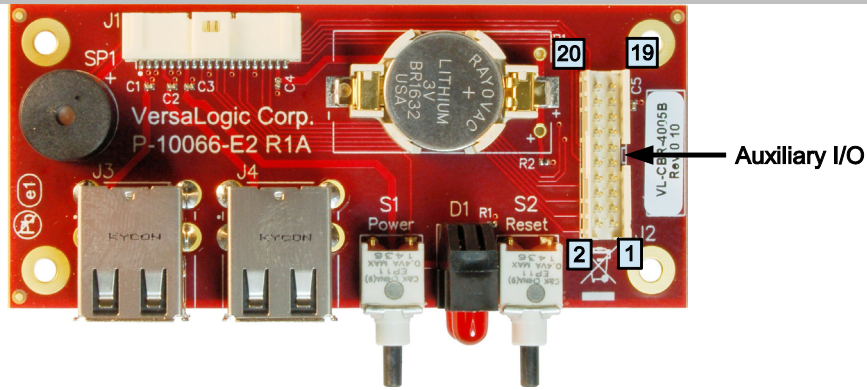
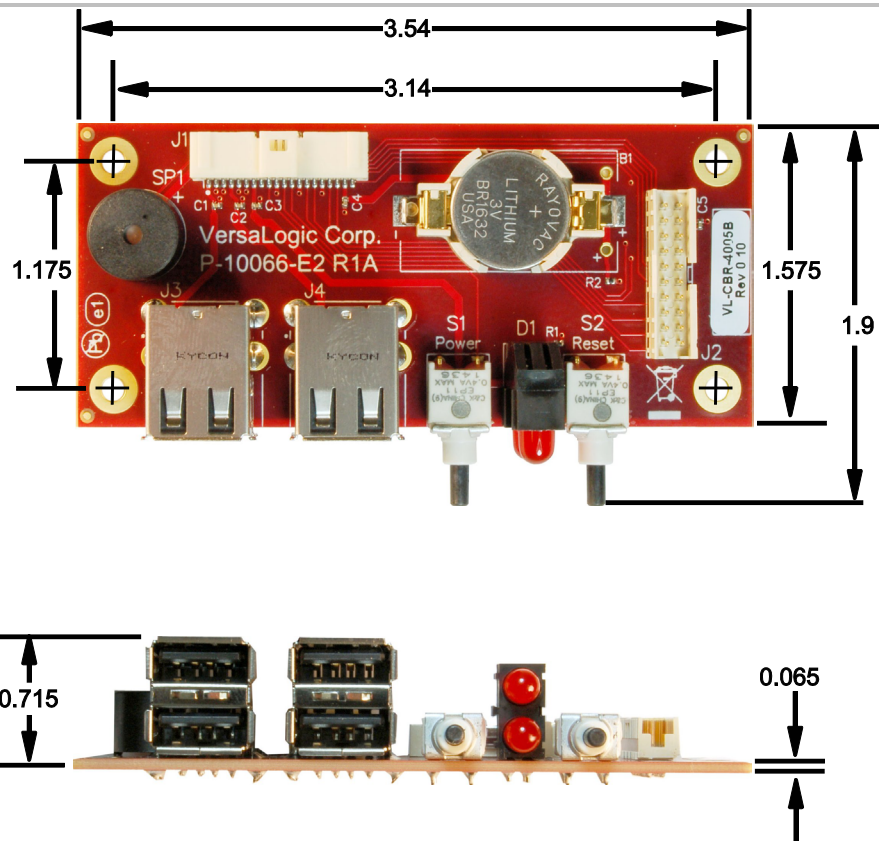

Table 16. Auxiliary I/O Connector Pinout

Pin	Signal	Pin	Signal
1	I2C Clock	2	V_BATT
3	I2C Data	4	V_BATT_RETURN
5	GND	6	GND
7	GPIO1	8	GPIO2
9	GPIO3	10	GPIO4
11	GND	12	GND
13	GPIO5	14	GPIO6
15	GPIO7	16	GPIO8
17	+3.3 V	18	GND
19	Ethernet Port 0 LED	20	Ethernet Port 1 LED

## Dimensions and Mounting Holes

Figure 26. VL-CBR-4005B Dimensions and Mounting Holes



## Thermal Considerations

This chapter discusses the following topics related to thermal issues:

- Selecting the correct thermal solution for your application
- EPU-4460 thermal characterization
- Installing the passive (HDW-416 heat sink), the active (HDW-415 fan), thermal solutions available from VersaLogic

### Selecting the Correct Thermal Solution for Your Application

This section provides guidelines for the overall system thermal engineering effort.

#### Heat Plate

The heat plate supplied with the Condor is the basis of the thermal solution. The heat plate draws heat away from the CPU chip as well as other critical components. Some components rely on the ambient air temperature at or below the maximum specified 85 °C temperature.

The design of the heat plate assumes that the user's thermal solution will maintain the top surface of the heat plate at 90 °C or less. If that temperature threshold is maintained, the CPU will remain safely within its operating temperature limits.



#### CAUTION:

By itself, the heat plate is not a complete thermal solution. Integrators should either implement a thermal solution using the accessories available from VersaLogic or develop their own thermal solution that attaches to the heat plate, suitable for environments in which the EPU-4460 will be used. As stated above, the thermal solution must be capable of keeping the top surface of the heat plate at or below 90 °C and the air surrounding the components in the assembly at or below 85 °C.

The heat plate is permanently affixed to the Condor and must not be removed. Removal of the heat plate voids the product warranty. Attempting to operate the Condor without the heat plate voids the product warranty and can damage the CPU.

#### System-level Considerations

The Condor is often mounted directly to another thermally controlled surface via its heat plate (that is, the inside surface of an enclosure). In this case, the user needs to maintain the heat plate at or below 90 °C by controlling the mounting surface temperature. The EPU-4460 thermal solutions available from VersaLogic – the HDW-406 heat sink with or without the HDW-415 fan, or the HDW-408 heat pipe block – can be used in the user's final system or only used during product development as a temporary bench-top solution.

The ambient air surrounding the EPU-4460 needs to be maintained at 85 °C or below. This may prove to be challenging depending on how and where the EPU-4460 is mounted in the end user system.

The decision which thermal solution to use relies on several factors including:

- Number of CPU cores in the SoC (single, dual, or quad)
- CPU and video processing utilization by the user application
- Temperature range within which the EPU-4460 will be operated
- Air movement (or lack of air movement)

Most of these factors involve the demands of the user application on the EPU-4460 and cannot be isolated from the overall thermal performance. Due to the interaction of the user application, the Condor thermal solution, and the overall environment of the end system, thermal performance cannot be rigidly defined.

The ambient air surrounding the EPU-4460 needs to be maintained at 85 °C or below. This would include the space between the two main boards as well as the space beneath an installed Mini PCIe expansion board. Standard methods for addressing this requirement include the following:

- Provide a typical airflow of 100 linear feet per minute (LFM) / 0.5 linear meters per second (as described in the section titled EPU-4460 Thermal Characterization, beginning on page 56) within the enclosure
- Position the EPU-4460 board to allow for convective airflow
- Lower the system level temperature requirement as needed

### CPU Thermal Trip Points

The CPU cores in the Condor have their own thermal sensors. Coupled with these sensors are specific reactions to three thermal trip points. Table 17 describes the three thermal trip points. Note that these are internal temperatures that are about 10 °C above the heat plate temperature.

**Table 17. CPU Thermal Trip Points**

Trip Point	Description
Passive (Note 1)	At this temperature, the CPU cores throttle back to a lower speed. This reduces the power draw and heat dissipation, but lowers the processing speed.
Critical (Note 2)	At this temperature, the operating system typically puts the board into a sleep or other low-power state.
Maximum core temperature	The CPU turns itself off when this temperature is reached. This is a fixed trip point and cannot be adjusted.

**Notes:**

1. The default value in the BIOS Setup utility for this trip point is 90 °C.
2. The default value in the BIOS Setup utility for this trip point is 100 °C.

These trip points allow maximum CPU operational performance while maintaining the lowest CPU temperature possible. The long-term reliability of any electronic component degrades when it is continually run near its maximum thermal limit. Ideally, the CPU core temperatures will be kept well below 100 °C with only brief excursions above.

CPU temperature monitoring programs are available to run under both Windows and Linux. Table 18 lists some of these hardware monitoring programs.

**Table 18. Temperature Monitoring Programs**

Operating System	Program Type	Description
Windows	Core Temperature	<a href="http://www.alcpu.com/CoreTemp/">http://www.alcpu.com/CoreTemp/</a>
	Hardware Monitor	<a href="http://www.cpubid.com/software/hwmonitor.html">http://www.cpubid.com/software/hwmonitor.html</a>
	Open Hardware Monitor	<a href="http://openhardwaremonitor.org/">http://openhardwaremonitor.org/</a>
Linux	lm-sensors	<a href="http://en.wikipedia.org/wiki/Lm_sensors">http://en.wikipedia.org/wiki/Lm_sensors</a>

### Thermal Specifications, Restrictions, and Conditions

Graphical test data is in the section titled EPU-4460 Thermal Characterization, beginning on page 56. Refer to that section for the details behind these specifications. These specifications are the thermal limits for using the EPU-4460 with one of the defined thermal solutions.

Due to the unknown nature of the entire thermal system, or the performance requirement of the application, VersaLogic cannot recommend a particular thermal solution. This information is intended to provide guidance in the design of an overall thermal system solution.

**Table 19. Absolute Minimum and Maximum Air Temperatures**

Board	With Heat Plate	With Heat Sink (HDW-416)	With Heat Sink + Fan (HDW-416 + HDW-415)
VL-EPU-4460-EAP	-40 ° to +85 °C	-40 ° to +85 °C	-40 ° to +85 °C
VL-EPU-4460-EBP	-40 ° to +85 °C	-40 ° to +85 °C	-40 ° to +85 °C
VL-EPU-4460-ECP	-40 ° to +85 °C	-40 ° to +85 °C	-40 ° to +85 °C

### Overall Restrictions and Conditions:

- Ranges shown assume less than 90% CPU utilization.
- Keep the maximum CPU core temperature below 100°C.
- The ambient air surrounding the EPU-4460 needs to be maintained at 85 °C or below. This includes the space between the two main boards as well as the space beneath an installed Mini PCIe expansion board. A required overall airflow of 100 linear feet per minute (LFM) / 0.5 linear meters per second (LMS) addresses this requirement. If this air flow is not provided, other means must be implemented to keep the adjacent air at 85 °C or below.

### Heat Plate Only Restrictions and Conditions:

- The heat plate must be kept below 90 °C. This applies to a heat plate mounted directly to another surface as well as when the HDW-408 heat pipe block is used.

### Heat Sink Only Considerations:

- At 85°C air temperature and 90% CPU utilization, there will be little if any thermal margin to a CPU core temperature of 100 °C or the passive trip point (see test data). If this is the use case, consider adding a fan or other additional airflow.

### Heat Sink with Fan Considerations:

- The heat sink and fan combination cools the CPU when it is running in high temperature environments, or when the application software is heavily utilizing the CPU or video circuitry. The fan assists in cooling the heat sink and provides additional air movement within the system.

 **Integrator’s Note:** The ambient air surrounding the EPU-4460 needs to be maintained at 85 °C or below.

## EPU-4460 Thermal Characterization

The EPU-4460 board underwent the following thermal characterization tests:

- Test Scenario 1: Dual core EPU-4460-EAP (Active and passive)
- Test Scenario 2: Dual core EPU-4460-EBP (Active and passive)
- Test Scenario 3: Dual core EPU-4460-ECP (Active and passive)

This table describes the thermal testing setup for the board.

**Table 20. EPU-4460 Thermal Testing Setup**

<b>Hardware Configuration</b>	EPU-4460 (Condor) dual core CPU with: <ul style="list-style-type: none"> <li>▪ 32 GB of DDR4 DRAM (2 GB for the single- and dual-core board models)</li> <li>▪ HDW-416 (passive heat sink)</li> <li>▪ HDW-415 (heat sink fan)</li> <li>▪ One VGA display device (connected through the LVDS interface), one display for monitor</li> <li>▪ One SATA hard disk drive</li> <li>▪ Two RS-232 ports in loopback configuration</li> <li>▪ Two VersaLogic VL-MPEe-E3 Mini PCIe Gigabit Ethernet modules</li> <li>▪ Two active Ethernet ports in loopback configuration</li> <li>▪ Two USB 2.0 ports in loopback configuration (<b>Note</b>)</li> <li>▪ USB keyboard and mouse (<b>Note</b>)</li> </ul>
<b>BIOS</b>	<ul style="list-style-type: none"> <li>▪ VER2C101</li> <li>▪ Passive thermal trip point setting: 105 °C</li> <li>▪ Critical thermal trip point setting: 111 °C</li> </ul>
<b>Operating System</b>	<ul style="list-style-type: none"> <li>▪ Microsoft Windows 10 Enterprise</li> </ul>
<b>Test Software</b>	<ul style="list-style-type: none"> <li>▪ Passmark BurnIn Test v8.1 b1018 - CPU utilization ~90%</li> <li>▪ Intel Thermal Analysis Tool (TAT) v5.0.1026 - Primarily used to read the CPU core temperature</li> </ul>
<b>Test Environment</b>	<ul style="list-style-type: none"> <li>▪ Thermal chamber</li> </ul>

**Note:** This device connects through a VersaLogic VL-CBR-4005B paddleboard.

The test results reflect the test environment within the temperature chamber used. The airflow of this particular chamber is about 0.5 linear meters per second (~100 linear feet per minute). Thermal performance improves by increasing the airflow beyond 0.5 linear meters per second.



The system power dissipation is primarily dependent on the application program; that is, its use of computing or I/O resources. The stress levels used in this testing are at the top of the range of a typical user's needs.

**Test Results**

**Test Scenario 1: Dual Core EPU-4460-EAP + HDW-416 Heat Sink, with/without HDW-415 fan**

The thermal characterization for the EPU-4460-EAP model (Intel Core i3) is shown below.

**Figure 27. EPU-4460-EAP Dual Core Temperature Relative to Ambient Temperature**

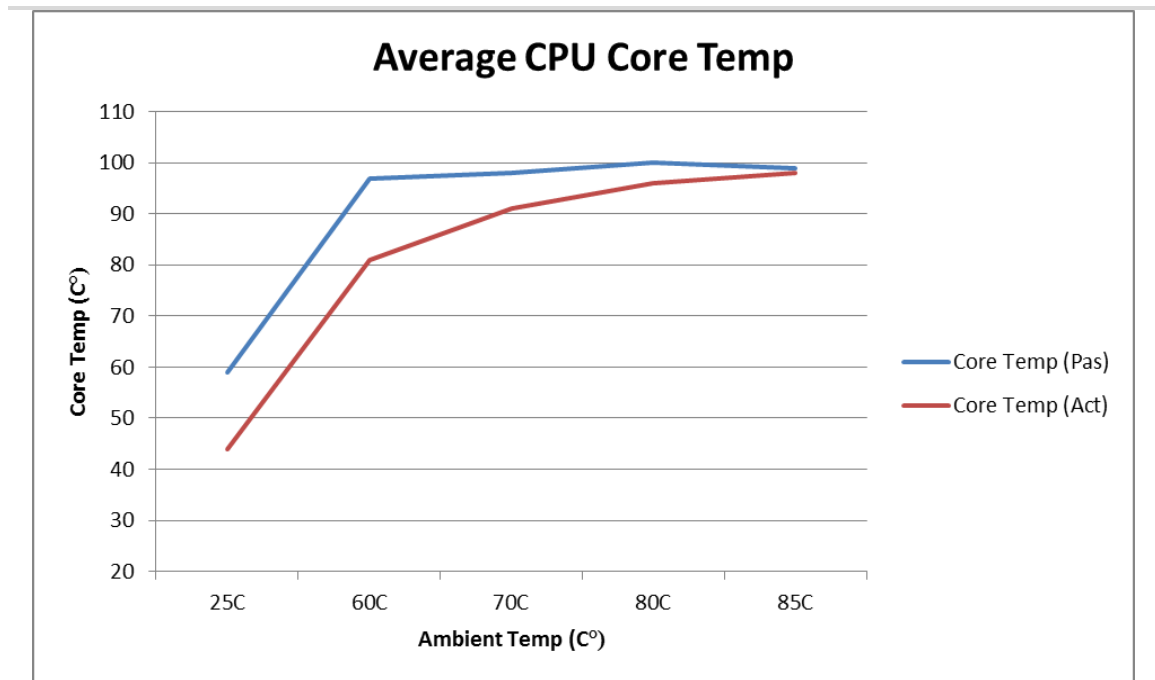

**Test Scenario 2: Dual Core EPU-4460-EBP + HDW-416 Heat Sink, with/without HDW-415 fan**  
The thermal characterization for the EPU-4460-EBP model (Intel Core i5) is shown below.

**Figure 28. EPU-4460-EBP Dual Core Temperature Relative to Ambient Temperature**

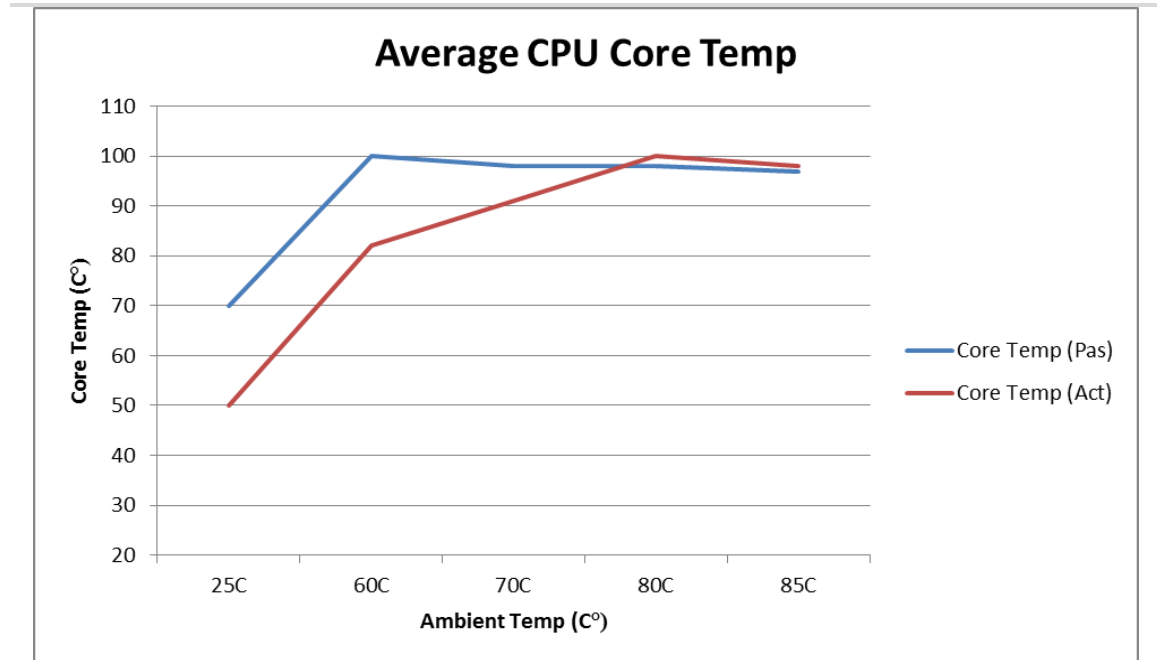

### Test Scenario 3: Dual Core EPU-4460-EDP + HDW-416 Heat Sink, with/without HDW-415 Fan

Figure 29. EPU-4460-ECP Dual Core Temperature Relative to Ambient Temperature

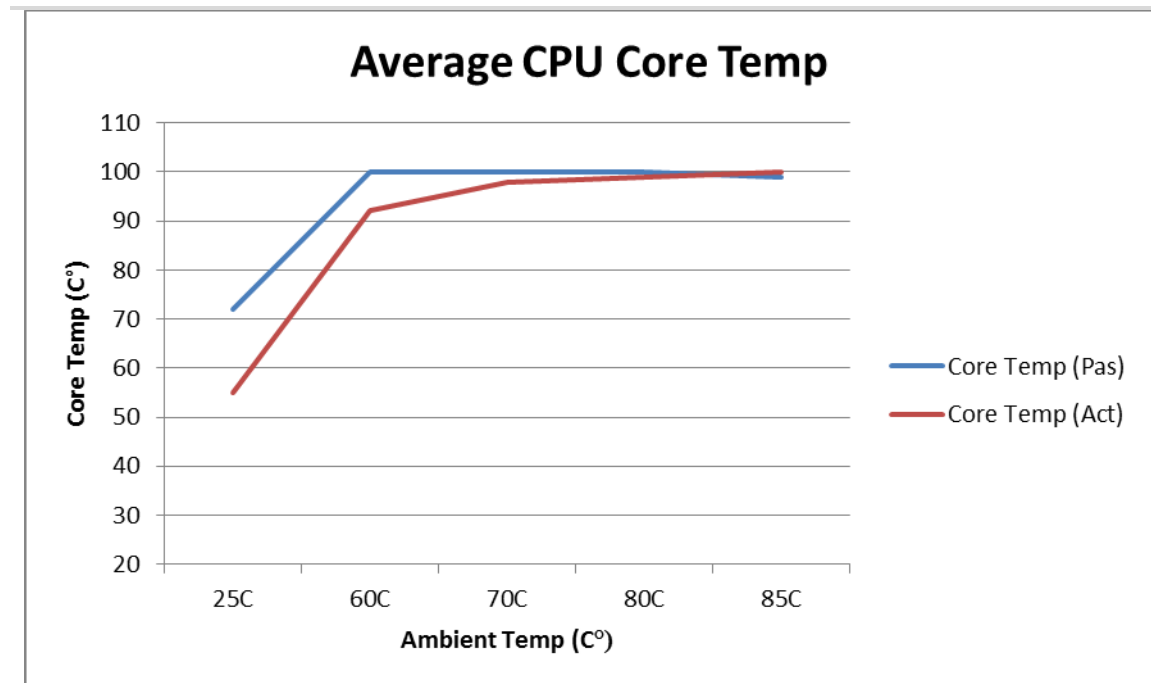

## Installing VersaLogic Thermal Solutions

The following thermal solution accessories are available from VersaLogic:

- VL-HDW-401 Thermal Compound Paste – used to mount the heat sink to the heat plate
- VL-HDW-416 Passive Heat Sink – mounts to standard product.
- VL-HDW-415 Fan Assembly – Cooling fan for the HDW-416 passive heatsink. Operates at +12 V and includes an EPU-4460 compatible connector
- VL-HDW-408 Heat Pipe Block – mounts to heat plate

### Hardware Assembly

There are two basic assembly methods:

- Heat plate down (in relation to the enclosure)
- Heat plate up

These assembly methods are shown in Figure 30 and Figure 31 respectively.

#### Heat Plate Down

The next figure (a representative image of a similar VersaLogic product) shows the assembly. Use this assembly method if you are attaching the Condor to a larger thermal solution such as a metal chassis/enclosure.

1. Attach the baseboard to the enclosure with standoffs.

**Figure 30. Heat Plate Down**

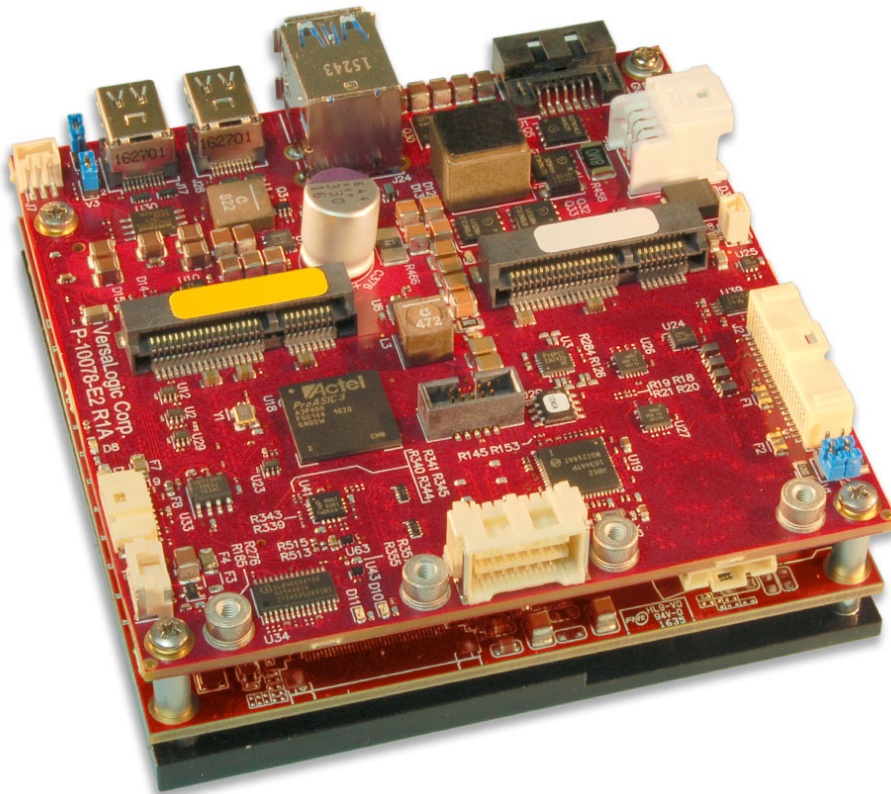

### Installing the VL-HDW-416 Passive Heat Sink

1. **Apply the Arctic Silver<sup>®</sup> Thermal Compound (VL-HDW-401)**
  - Apply the thermal compound to the heat plate using the method described on the Arctic Silver website - <http://www.arcticsilver.com/>
2. **Position the passive heat sink**
  - Using the figure below as a guide, align the five mounting holes of the heat sink with the heat plate.
  - Orient the heat sink fins in the direction of the system airflow to maximize CPU cooling.
3. **Secure the passive heat sink to the heat plate**
  - Affix the passive heat sink to the heat plate using five M2.5 pan head screws.
  - Using a torque screwdriver, tighten the screws to 4.0 inch-pounds.

**Figure 31. Installing the Passive Heat Sink**

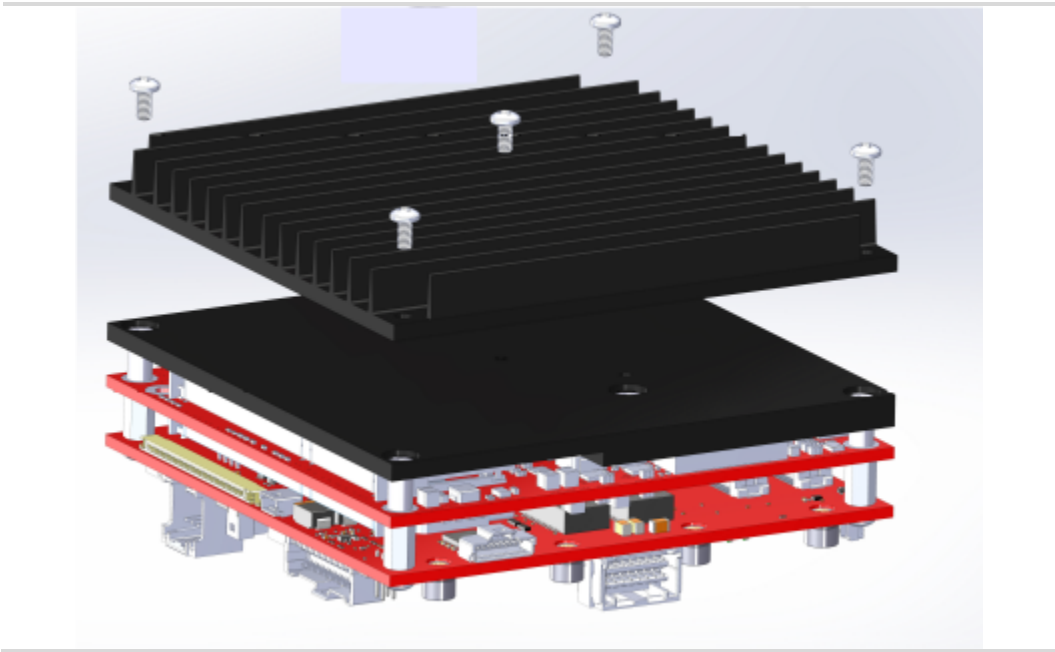

## Installing the VL-HDW-415 Heat Sink Fan

### 1. Position the fan assembly

- Using the figure below as a guide, align the mounting holes of the heat sink fan with the four holes in the passive heat sink. Position the fan so that its power cable can easily reach its mate.

### 2. Secure the fan to the heat sink

- Affix the heat sink fan using four M3 pan head screws.
- Using a torque screwdriver, tighten the screws to 4.0 inch-pounds.

### 3. Connect power to the fan

- Connect the fan's power cable to J18 on the EPU-4460.

Figure 32. Installing the Heat Sink Fan

